

## LICENSING SUB-COMMITTEE

**Date:** Wednesday 15 April 2026

**Time:** 10.00 am

**Venue:** Bad Homburg Room, Civic Centre, Paris Street, Exeter

Members are invited to attend the above meeting to consider the items of business.

If you have an enquiry regarding any items on this agenda, please contact Josie McDonald, Democratic Services Officer on 01392 265354 or email [democratic.services@exeter.gov.uk](mailto:democratic.services@exeter.gov.uk)

Entry to the Civic Centre can be gained through the Customer Service Centre, Paris Street.

*Membership -*

Councillors Darling, Holland and Williams, R

### Agenda

#### Part I: Items suggested for discussion with the press and public present

1 **Appointment of Chair**

To appoint a Chair for the meeting.

2 **Declarations of Interest**

Councillors are reminded of the need to declare any disclosable pecuniary interests that relate to business on the agenda and which have not already been included in the register of interests, before any discussion takes place on the item. Unless the interest is sensitive, you must also disclose the nature of the interest. In accordance with the Council's Code of Conduct, you must then leave the room and must not participate in any further discussion of the item. Councillors requiring clarification should seek the advice of the Monitoring Officer prior to the day of the meeting.

3 **LOCAL GOVERNMENT (ACCESS TO INFORMATION) ACT 1985 EXCLUSION OF PRESS AND PUBLIC**

It is considered unlikely that the Committee would wish to exclude the press and public during consideration of the items on this agenda. If, however, the Committee were to exclude the press and public, a resolution in the following form should be passed:

**"RECOMMENDED** that, under Section 100A(4) of the Local Government Act 1972, the press and public will be excluded from the meeting for the particular item(s) on the grounds that it (they) involve the likely disclosure of the exempt information as defined in paragraph(s) of Part 1 of Schedule 12A of the Act".

**LOCAL GOVERNMENT (MISCELLANEOUS PROVISIONS) ACT 1976**

**LOCAL GOVERNMENT (MISCELLANEOUS PROVISIONS) ACT 1982**

- 4 **Application to Renew Hackney Carriage Vehicle licence over 9 years old**  
To consider the report of the Head of Service - Environment and Waste. (Pages 3 - 38)
- 5 **Application to Renew a Private Hire Vehicle licence over 10 years old**  
To receive the report of the Head of Service – Environment and Waste. (Pages 39 - 76)
- 6 **Application to Renew a Private Hire Vehicle licence over 10 years old**  
To receive the report of the Head of Service – Environment and Waste. (Pages 77 - 108)

**TOWN POLICE CLAUSES ACT 1847**

- 7 **Hearing to Determine Whether a Holder of a Hackney Carriage / Private Hire Drivers Licence is a fit and proper person to hold a the licence**  
To consider the report of the Head of Service - Environment and Waste. (Pages 109 - 124)

**Individual reports on this agenda can be produced in other formats on request to Democratic Services .**

## REPORT TO LICENSING SUB COMMITTEE

**Date of Hearing:** 15 April 2026

**Report of:** Julie Bennett Licensing Officer

**Type of Application:** RENEWAL of a licence relating to a Hackney Carriage vehicle over 9 years old.

**Legislation:** Local Government (Miscellaneous Provisions) Act 1976, Town Police Clauses Act 1847

**Applicant:** Ullah Noor

### 1. What is the report about?

- 1.1 An application attached at Appendix A has been received from the Applicant, a licensed taxi driver seeking permission for the renewal of a hackney carriage licence for a vehicle which is 10 years old on 19 September 2026. This is a matter that cannot be dealt with under delegated powers.

### 2. Background:

- 2.1 The vehicle that is being presented for licensing as a hackney carriage vehicle is a 4 passenger, Peugeot Horizon, registration number SF66 FGZ, with a date of first registration of 19 September 2016. A copy of the vehicle registration document is attached as Appendix B.

### 3. Report Details:

- 3.1 The vehicle has a current MOT certificate dated 24 February 2026 and expires 7 March 2027. The mileage recorded at the MOT inspection was 173,719 miles. The MOT certificate and history are attached as Appendix C. The MOT history shows that the vehicle has failed the MOT test on 5 occasions since 2021. In addition to the MOT certificate there is an independent mechanical inspection report, which has been submitted, this is dated 4 March 2026 and is attached as Appendix D. Photos of the vehicle are attached at Appendix E. Upon inspection by a Council Officer the vehicle was found to be in reasonable condition for the age. The vehicle was first plated by Exeter City Council on 11 March 2019 and has been licensed since that date. The vehicle was transferred to the Applicant on 24 September 2021.
- 3.2 The Licensing Sub-Committee must have regard to the Council's the Practices and Procedures for the control of Hackney Carriage and Private Hire Vehicles, Drivers and Operators and the Code of Conduct for Licensed Drivers ('Taxi Policy').
- 3.3 Vehicles presented for renewal that are more than 8 years old will be referred to the licensing sub-committee for determination.

#### **4. What are the legal aspects?**

- 4.1 Section 37 of the Town Police Clauses Act 1847 provides that a district council may grant a vehicle a Hackney Carriage Licence. Section 47 of the Local Government (Miscellaneous Provisions) Act 1976 ('the Act') states that a district council may attach such conditions to a licence as it considers reasonably necessary. The conditions that may apply are set out in the Taxi Policy.
- 4.2 Any person aggrieved by a refusal of the Licensing Sub-Committee to grant a vehicle licence may appeal to the Magistrates Court within 21 days of receiving written notice of the refusal.

#### **5. Recommendations:**

- 5.1 The Licensing Sub-Committee are asked to determine the application having regard to current policy.

#### **Service Lead – Head of Environment and Waste**

Author: Julie Bennett – Licensing Officer

#### **Local Government (Access to Information) Act 1972 (as amended)**

Background papers used in compiling this report:-  
None

Contact for enquires:  
Democratic Services  
Democratic.services@exeter.gov.uk  
01392 265354

# **APPENDIX A**

**APPLICATION FOR THE RENEWAL OF A  
A HACKNEY CARRIAGE OR PRIVATE HIRE VEHICLE LICENCE**

*(Some details on this form are pre-filled from our records – if any of these details are incorrect, please use the blank space provided to give the correct details)*

<b>Name:</b>	[REDACTED]		
<b>Address:</b>	[REDACTED]		
<b>Telephone</b>		<b>Email:</b>	[REDACTED]
<b>Mobile</b>	[REDACTED]	<b>Vehicle registration number</b>	[REDACTED]
<b>Type of licence held:</b>	Hackney Carriage Vehicle	<b>Vehicle Plate Number:</b>	[REDACTED]
<b>Licence expiry date:</b>	10 March 2026	<b>Driver Licence No.</b>	

Any other person who is a proprietor of the vehicle or who is concerned either solely or in partnership with any other person in the keeping, employing or letting of hire of the vehicle.

Name	Address

I hereby apply for a licence for the motor vehicle identified in this application to be used as a \*Hackney Carriage\* / \*Private Hire Vehicle\* within the City of Exeter and I hereby declare that all particulars entered on the form are true and correct to the best of my knowledge and belief. *(\*Delete which does not apply)*

VEHICLE DETAILS		
<b>Make of vehicle:</b>	<b>Model of vehicle:</b>	<b>Number of passengers:</b>
Peugeot	Horizon	4
<b>Vehicle Registration Document number:</b>		<b>Date of first registration:</b>
		19.09.2016
<b>Details of current vehicle insurance:</b>		<b>Date insurance expires:</b>
FULL		[REDACTED]

--	--

<b>Where will the vehicle be kept when not in use? (address):</b>	

In respect of Private Hire Vehicles, by which Operator, and from what address will the Private Hire Vehicle be operated?	
<b>Name of Operator:</b>	
<b>Address of Operator:</b>	

**When an application involves the substitution or exchange of an existing vehicle by a new one, please answer the following questions:**

Will the replaced vehicle continue to be used as a Licenced Private Hire/Hackney Carriage vehicle?	<b>YES</b>	<b>NO</b>
If NO, please specify reason: (i.e. private use, taken off road, etc.)		
If continuing to be used as a Licenced vehicle, please give name and address of new owner:		
Make of existing licenced vehicle:	Peugeot	
Registration number of existing licenced vehicle:	SF66 FGZ	

I understand that omissions or incorrect statements will render the Licence if granted, liable to suspension or revocation and render me liable to prosecution.

I have been given a copy of the conditions relating to this Licence.

SIGNE  DATED **01/03/2026**

See over for notes.

This page is intentionally left blank

# **APPENDIX B**



**Driver & Vehicle Licensing Agency**

Registration number



**UNITED KINGDOM  
UK REGISTRATION CERTIFICATE**

958\_1050221815\_01109\_0030\_40400A



**Registered keeper**

You **must** make sure that the name and address printed here is correct. If it is not, see section 3.

Document reference number  
Don't share, keep it safe



Acquired vehicle on 02 08 2021



**Thinking of buying this vehicle?  
Buyer beware...**

Do you know how to avoid being tricked into buying a stolen vehicle?

For tips and advice go to [gov.uk/checks-when-buying-a-used-car](http://gov.uk/checks-when-buying-a-used-car)



**THIS DOCUMENT IS NOT PROOF OF OWNERSHIP.**  
It shows who is responsible for registering and taxing the vehicle.

**Registration Certificate translations**

Document des données de circulation Dokumente o registraciji Registrierungsbescheinigung	Zulassungsbescheinigung Registrierungsbescheinigung Attesto sul proprietario/ Dokumentacija o registraciji	Certificat d'immatricolazione Tasasiz Clartite Carta de circulație Registrační příloha	Registrierbescheinigung Fornitori ogjendry Certifikat të Regjistrimit Kantakarbepis	Dowód Rejestracyjny Certificat de matricolă Certificat de immatricolare QovodCenë e evidencë	Pravilnica dovoljenja Faislata detritokutur Registrierungsbescheinigung Pravilnica dovoljenja
--	---	---	--	---	--

**Data protection**

DVLA handles your personal data in accordance with road vehicle law and data protection laws. The law allows us to release your data to the police and other enforcement bodies. We also provide data to other parties where the law allows it. For further information about how we process your data, your rights and who to contact, see our [privacy notice at gov.uk/dvla/privacy-policy](http://gov.uk/dvla/privacy-policy)

**Special notes (these notes cannot be removed)**

NO. OF FORMER KEEPERS 3  
1. DECLARED NEW AT FIRST REGISTRATION.

**How to fill in your V5C Registration Certificate (log book)**

**Tax or SORN (Statutory Off Road Notification) using the document reference number above.**

<p><b>1</b> Change my vehicle details</p> <p>You must fill in section 1 over the page and return the whole V5C to DVLA, Swansea, SA99 1BA. For more information go to: <a href="http://gov.uk/change-vehicle-details-registration-certificate">gov.uk/change-vehicle-details-registration-certificate</a></p>	<p><b>2</b> Selling or transferring my vehicle to a new keeper (not a trader)</p> <p>It's quick and simple to tell us online at: <a href="http://gov.uk/sold-bought-vehicle">gov.uk/sold-bought-vehicle</a> Or fill in section 2 over the page and send to DVLA, Swansea, SA99 1BA. You must give section 6 to the new keeper.</p>	<p><b>3</b> Change my name and / or address</p> <p>It's quick and simple to tell us your new address online at: <a href="http://gov.uk/change-address-v5c">gov.uk/change-address-v5c</a> Or if your name and address has changed you must fill in section 3 over the page and return the whole V5C to DVLA, Swansea, SA99 1BA.</p>	<p><b>4</b> Selling, transferring or part exchanging this vehicle to a motor trader</p> <p>It's quick and simple to tell us online at: <a href="http://gov.uk/sold-bought-vehicle">gov.uk/sold-bought-vehicle</a> Or fill in section 4 over the page and return just that page to DVLA, Swansea, SA99 1BA.</p>	<p><b>5</b> Permanently exporting this vehicle for more than 12 months</p> <p>If you or someone you're selling the vehicle to is taking it out of the country for 12 months or more, go to section 5 over the page. For more information go to: <a href="http://gov.uk/taking-vehicles-out-of-uk">gov.uk/taking-vehicles-out-of-uk</a></p>	<p><b>6</b> New keeper slip</p> <p>Selling your vehicle: you must fill in the date of sale on section 6 over the page and give it to the new keeper. <b>Vehicle tax or SORN isn't passed on to someone else.</b> For more information go to: <a href="http://gov.uk/vehicletaxrules">gov.uk/vehicletaxrules</a></p>
---	--	--	--	--	---

**Failure to tell DVLA of any changes may result in a penalty and / or prosecution.**

V5C-0720

### Vehicle details

Official use only

**A** Registration number: [REDACTED] **[A.1]** 5

**B** Date of first registration: 19 09 2010  
**(B.1)** Date of first registration in the UK: 19 09 2010  
**D.1** Make: PEUGEOT  
**D.2** Type: 7  
 Variant: J8HY  
 Version: M3PS-3

Euro class:  
 Fuel driving emissions:  
**D.3** Model: HORIZON RC  
**D.4** Body type: MPV  
**D.5** Taxation class: DIESEL CAR  
**(D.6)** Subcategory type:  
**(V)** Revenue weight: 1612.0 KG UNLADEN  
**F1** Cylinder capacity (cc): 1500 CC  
**V7** CO<sub>2</sub> (g/km): 109 g/km  
**F2** Type of fuel: HEAVY OIL  
**S.1** Number of seats including driver: 3  
**S.2** Number of standing places (M099, M099A, M099B):  
**(D.4)** Wheelplan: 2-AXLE-RIGID BODY  
**J** Vehicle category: M3  
**K** Type approval number: C11\*200746\*3133\*00  
**P2** Max. net power (kW): 73

**E** VIN/Chassis/Frame No.: [REDACTED]  
**F3** Engine number: [REDACTED]  
**F1** Max. permissible mass (acc. MVD): 2075  
**Q** Mass in service: 1667  
**Q** Power/brake ratio (kW/kg) (only for motorcycles):  
**R** Colour: GREY  
**O** Technical permissible maximum towable mass of trailer:  
**O.1** towed (kg):  
**O.2** unbraked (kg):  
**U** Sound level:  
**U.1** stationary (dB(A)) 76  
**U.2** engine speed (min-1) 2813  
**U.3** drive-by (dB(A)) 73  
**V** Exhaust Emissions:  
**V1** CO (g/km or g/kWh): 0.179  
**V2** HC (g/km or g/kWh):  
**V3** NOx (g/km or g/kWh): 0.046  
**V4** HC+NOx (g/km): 0.058  
**V5** permissible (g/km or g/kWh):  
 Automated vehicle (AV):

### 1 Change my vehicle details - Only fill in details to be corrected or changed **H**

By submitting this form you are declaring that the information provided is correct. If you have made changes to your vehicle or if the information above is incorrect, you must

fill us by filling in the relevant boxes below and send whole V5C to DVLA, Swansea, SA99 1SA. Use black ink and CAPITALS.

Registration number: [REDACTED] **5**

Document reference number: 1224 848 0631

Wheelplan / Body type:

VIN / Chassis / Frame number:

New revenue weight:      Date of change:      Cylinder capacity (cc):

No. of seats inc. driver:      No. of standing places:      Type of fuel:

Engine number:

New colour:      Date of change:      CLR

Tax class:      **Y**

For information on how to change your tax class go to [gov.uk/change-vehicle-tax-class](http://gov.uk/change-vehicle-tax-class)

### 2 Selling or transferring my vehicle to a new keeper (not a trader) **W**

By submitting this form you are declaring that the information provided is correct. You must tell us immediately if you have sold or transferred your vehicle. It's quick and simple to tell us online. If you don't receive an acknowledgment or tax refund, if applicable, go to [gov.uk/contact-the-dvla](http://gov.uk/contact-the-dvla) as you may still be liable. If you want to keep the registration number you must do this before you sell or transfer it. To tell us go to [gov.uk/keep-registration-number](http://gov.uk/keep-registration-number)

You can use this form to tell us if you have:  
• Sold your vehicle privately - fill in the boxes below and the date of sale on section 6 over the page. Use black ink and CAPITALS. Tear off section 6 (green slip) give it to the new keeper. Return the rest of the V5C to DVLA, Swansea, SA99 1SA.  
• Sold, transferred or part exchanged your vehicle to a motor trader - go to section 4 (yellow sections) on the next page.

Registration number: [REDACTED] **5**

Document reference number: 1224 848 0631

Title: Mr  Mrs  Miss

Or other title or business / company name:

New keeper's first and middle names written in full:

Surname:

DVLA fleet number for companies only:      Date of birth (optional):

Current UK address (house number, street name, town / city):  
 Foreign address? For information go to [gov.uk/taking-vehicle-out-of-uk](http://gov.uk/taking-vehicle-out-of-uk)

Postcode:      Mileage (optional):

Date of sale (mandatory):      **K**

Contact number of the new keeper (optional):  
 Email address of the new keeper (optional):  
 Driving licence number of the new keeper (optional):

Official use only. Do not write in this space.

1224 848 0631      12 08 21  
958 / 1050221015 / 01109      41



[REDACTED] **5**

V5C-0720

Official use only

### 3 Change my name and / or address – Enter full details for all changes

By submitting this form you are declaring that the information provided is correct. If your personal details are wrong or have changed, you must tell us by filling in the boxes below giving us your full name and/or address. Use black ink and CAPITALS. Send the whole V5C to DVLA, Swansea, SA99 1BA. For more information go to: gov.uk/change-address-v5c

Registration number: [redacted] 5 [redacted]

Document reference number: 1224 848 0631 [redacted]

Title: Mr  Mrs  Miss

Or other title or business / company name: [grid]

First and middle names written in full: [grid]

Surname: [grid]

New UK address (house number, street name, town / city): [grid]

Postcode: [grid]

Contact number (optional): [grid]

Email address (optional): [grid]

1224 848 0631 12 08 21  
958 / 1050221015 / 01109 41

### 4 Selling, transferring or part exchanging this vehicle to a motor trader

By submitting this form you are declaring that the information provided is correct. A motor trader can be: motor dealer, motor auctioneer, vehicle dismantler, salvage dealer, finance and leasing company, insurance company, or car buying service. If you want to keep the registration number you must do this before you sell or transfer it. To tell us go to: gov.uk/keep-registration-number

Registration number: [redacted] 5 [redacted]

Document reference number: [redacted]

03 Date of sale (mandatory): [grid]

Mileage (optional): [grid]

Name and address of motor trader: [grid]

VAT number: [grid] Postcode: [grid]

### 5 Permanently exporting this vehicle for more than 12 months

By submitting this form you are declaring that the information provided is correct. If you are taking the vehicle out of the country for 12 months or more as permanent export you must fill in the boxes below. Use black ink and CAPITALS. Tear along the red perforated line and send the whole section to DVLA, Swansea, SA99 1BA. You must keep the rest of your V5C – you will need this to re-register your vehicle abroad. If you're selling the vehicle to a new keeper with a foreign address go to: gov.uk/selling-vehicles-out-of-uk

Registration number: [redacted] 5 [redacted]

Document reference number: [redacted]

Date of export: [grid]

Which country are you exporting the vehicle to? [grid]

### 6 New keeper slip – must be given to the new keeper

Do not send this slip to DVLA on its own – you won't get a V5C. You, the new keeper, must ensure the vehicle is taxed before you drive it. You will be fined if our records show that the vehicle is not taxed, insured or has Standard Of Road Notification (SORN) has been made. It's quick and simple to tax online at gov.uk/vehicle-tax or tax at a Post Office\* using this slip. Delete the vehicle off road online at gov.uk/make-a-rom. You should receive your new V5C within 4 weeks of the registered keeper giving us your details. If you do not receive your V5C, you'll need to fill in a V5C form to apply for a new one. Send it, with this slip, to DVLA, Swansea, SA99 1DD. Make sure the date of sale/transfer box is filled in. For more details on this vehicle go to: gov.uk/get-vehicle-information-from-dvla. For data protection information go to: gov.uk/dpa/privacy-policy

Registration number: [redacted] 5 [redacted]

Document reference number (see this to tax online): [redacted]

Date of sale / transfer: [grid]

12 08 21 41

Make: PEUGEOT  
Model: HORIZON RE  
Colour: GREY  
Engine size: 1560 CC  
Suspension type: [redacted]  
Tax class: DIESEL CAR  
No. of seats: 3

Official use only. Do not write in this space.



6269 3321 2246 1067 2757 3141

# **APPENDIX C**

# MOT test certificate



Driver & Vehicle  
Standards  
Agency

Vehicle identification number  
[REDACTED]

Registration number [REDACTED] Country of registration  
GB

Make and model  
**PEUGEOT HORIZON**

Vehicle category	Mileage	Mileage history	
M1	173,719 miles	147,767 miles	19.02.2025
		119,131 miles	16.02.2024
		90,807 miles	07.03.2023

**Pass**

Date of the test 24.02.2026 Expiry date 07.03.2027

To preserve the anniversary of the expiry date, the earliest you can present your vehicle for test is 08.02.2027.

Location of the test  
[REDACTED]

Test centre location and inspector name  
[REDACTED]

MOT test number  
[REDACTED]

Check that this document is genuine by visiting [www.gov.uk/check-mot-history](http://www.gov.uk/check-mot-history)

If any of the details are not correct, please contact DVSA by email at [enquiries@dvsa.gov.uk](mailto:enquiries@dvsa.gov.uk) or by telephone on 0300 1239000.

Receive a free annual MOT reminder by subscribing at [www.gov.uk/mot-reminder](http://www.gov.uk/mot-reminder) or by telephone on 0300 1239000.

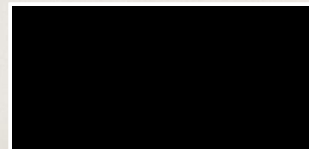

## Check the MOT history of a vehicle

Help us make this service better. Give us your [feedback](https://dvs.qualtrics.com/jfe/form/SV_7X2O0cNscPctIP4?vm=SF66FGZ&make_result=PEUGEOT&model_result=HORIZON&mot_first_used_date=2016-09-19&vehicle_age=3452&mot_expiry_date=2027-03-07&mot_expiry_date_days_left=369&user_satisfaction_banner=0&vehicle_data_origin=MTS&vehicle_type=LGV) ([https://dvs.qualtrics.com/jfe/form/SV\\_7X2O0cNscPctIP4?vm=SF66FGZ&make\\_result=PEUGEOT&model\\_result=HORIZON&mot\\_first\\_used\\_date=2016-09-19&vehicle\\_age=3452&mot\\_expiry\\_date=2027-03-07&mot\\_expiry\\_date\\_days\\_left=369&user\\_satisfaction\\_banner=0&vehicle\\_data\\_origin=MTS&vehicle\\_type=LGV](https://dvs.qualtrics.com/jfe/form/SV_7X2O0cNscPctIP4?vm=SF66FGZ&make_result=PEUGEOT&model_result=HORIZON&mot_first_used_date=2016-09-19&vehicle_age=3452&mot_expiry_date=2027-03-07&mot_expiry_date_days_left=369&user_satisfaction_banner=0&vehicle_data_origin=MTS&vehicle_type=LGV)).

[Back](#)

# PEUGEOT HORIZON

[Check another vehicle \(/\)](#)

Colour  
**Red**

Fuel type  
**Diesel**

Date registered  
**19 September 2016**

MOT valid until  
**7 March 2027**

[Get an MOT reminder \(https://www.gov.uk/mot-reminder\)](https://www.gov.uk/mot-reminder) by email or text.

[Download test certificates \(/enter-document-reference?registration=SF66FGZ\)](/enter-document-reference?registration=SF66FGZ)

You can [get information corrected on your MOT history \(https://www.gov.uk/getting-an-mot/correcting-mot-certificate-mistakes\)](https://www.gov.uk/getting-an-mot/correcting-mot-certificate-mistakes) (such as mileage or vehicle details) if it's wrong.

[Hide all sections](#)

## MOT history

Check mileage recorded at test, expiry date, and test outcome

[Hide](#)

Date tested  
**24 February 2026**

**PASS**

Mileage  
**173,719 miles**

Test location  
[View test location](#)

MOT test number

Expiry date  
**7 March 2027**

24 February 2026

173,719 miles

[REDACTED]

**FAIL**

Test location

▶ [View test location](#)

Do not drive until repaired (dangerous defects):

- **Front Brake pad(s) less than 1.5 mm thick (1.1.13 (a) (ii))**

▶ [What are defects?](#)

---

Date tested  
19 February 2025

Mileage  
147,767 miles

MOT test number

[REDACTED]

**PASS**

Test location

▶ [View test location](#)

Expiry date  
7 March 2026

---

Date tested  
19 February 2025

Mileage  
147,764 miles

MOT test number

[REDACTED]

**FAIL**

Test location

▶ [View test location](#)

Repair immediately (major defects):

- **Nearside Front Outer Drive shaft joint constant velocity boot split or insecure, no longer prevents the ingress of dirt split (6.1.7 (g) (ii))**
- **Offside Front Anti-roll bar linkage ball joint excessively worn (5.3.4 (a) (i))**

Repair as soon as possible (minor defects):

- **Offside Registration plate lamp inoperative in the case of multiple lamps or light sources (4.7.1 (b) (i))**

▶ [What are defects?](#)

---

Date tested  
16 February 2024

Mileage  
119,131 miles

MOT test number

[REDACTED]

**PASS**

Test location

▶ [View test location](#)

Expiry date  
7 March 2025

---

Date tested  
15 February 2024

Mileage  
119,127 miles

MOT test number

[REDACTED]

**FAIL**

Test location

▶ [View test location](#)

Do not drive until repaired (dangerous defects):

- **Nearside Front Track rod end ball joint worn to the extent there is a serious risk of detachment (2.1.3 (b) (ii))**

Repair immediately (major defects):

- **Exhaust system insecure (6.1.2 (a))**
- **Emissions unable to be completed (8.2.2.2 (e))**
- **Emissions unable to be completed (8.2.2.2 (e))**
- **Offside Front Brake hose excessively twisted (1.1.12 (b) (ii))**
- **Nearside Rear Direction indicator incorrect colour (4.4.3 (a))**
- **Offside Rear Direction indicator incorrect colour (4.4.3 (a))**
- **Offside Front Track rod end ball joint has excessive play (2.1.3 (b) (i))**
- **Offside Rear Coil spring corroded so that its cross sectional area is reduced and seriously weakened (5.3.1 (b) (i))**

Monitor and repair if necessary (advisories):

- **Exhaust has a minor leak of exhaust gases (6.1.2 (a))**
- **Oil leak, but not excessive (8.4.1 (a) (i))**
- **Nearside Front Brake hose slightly deteriorated (1.1.12 (b) (ii))**
- **Nearside Front Anti-roll bar linkage ball joint has slight play (5.3.4 (a) (i))**
- **Nearside Rear Coil spring corroded (5.3.1 (b) (i))**
- **Offside Front Lower Suspension arm ball joint has slight play (5.3.4 (a) (i))**

▶ [What are defects and advisories?](#)

---

Date tested  
**7 March 2023**

**PASS**

Mileage  
**90,807 miles**

Test location

▶ [View test location](#)

MOT test number

Expiry date  
**7 March 2024**

Repair as soon as possible (minor defects):

- **Offside Front Drive shaft joint constant velocity boot severely deteriorated (6.1.7 (g) (i))**
- **Nearside Registration plate lamp inoperative in the case of multiple lamps or light sources (4.7.1 (b) (i))**

▶ [What are defects and advisories?](#)

---

Date tested  
**21 February 2022**

Mileage  
**65,096 miles**

Test location

MOT test number

Expiry date

# PASS

▶ [View test location](#)

7 March 2023

Repair as soon as possible (minor defects):

- **Nearside Outer Drive shaft joint constant velocity boot severely deteriorated (6.1.7 (g) (i))**

Monitor and repair if necessary (advisories):

- **Nearside Rear Tyre worn close to legal limit/worn on edge (5.2.3 (e))**

▶ [What are advisories?](#)

---

Date tested  
21 February 2022

Mileage  
65,096 miles

MOT test number  
[REDACTED]

# FAIL

Test location

▶ [View test location](#)

Repair immediately (major defects):

- **Offside Front Position lamp not working (4.2.1 (a) (ii))**
- **Nearside Headlamp aim too high and too far to the left. (4.1.2 (a))**
- **Offside Headlamp aim too high and too far to the left. (4.1.2 (a))**

Repair as soon as possible (minor defects):

- **Nearside Outer Drive shaft joint constant velocity boot severely deteriorated (6.1.7 (g) (i))**

Monitor and repair if necessary (advisories):

- **Nearside Rear Tyre worn close to legal limit/worn on edge (5.2.3 (e))**

▶ [What are defects and advisories?](#)

---

Date tested  
8 March 2021

Mileage  
44,177 miles

MOT test number  
[REDACTED]

# PASS

Test location

▶ [View test location](#)

Expiry date  
7 March 2022

---

Date tested  
5 March 2021

Mileage  
44,176 miles

MOT test number  
[REDACTED]

# FAIL

Test location

▶ [View test location](#)

Repair immediately (major defects):

- **Brake pedal anti-slip provision missing (1.1.2 (c))**

- Registration plate lamp inoperative in the case of a single lamp or all lamps (4.7.1 (b) (ii))
- Nearside Side repeater not working (4.4.1 (a) (ii))

▶ [What are defects?](#)

---

Date tested  
**4 March 2020**

**PASS**

Mileage  
**31,684 miles**

Test location

▶ [View test location](#)

MOT test number

Expiry date  
**3 March 2021**

---

Date tested  
**15 June 2019**

**PASS**

Mileage  
**16,951 miles**

Test location

▶ [View test location](#)

MOT test number

Expiry date  
**14 June 2020**

---

### The MOT test changed on 20 May 2018

Defects are now categorised according to their severity - dangerous, major, and minor. [Find out more \(https://www.gov.uk/government/news/mot-changes-20-may-2018\)](https://www.gov.uk/government/news/mot-changes-20-may-2018).

---

## Safety recalls

We do not have recall information for this vehicle.

Contact your local PEUGEOT dealership to check if the vehicle has been recalled.



[Cookies](#) [Terms and conditions](#) [Privacy notice](#) [Accessibility statement](#)  
[MOT history API](#) [Service status](#)

Built by the [Driver & Vehicle Standards Agency](#)

**OGL**

All content is available under the [Open Government Licence v3.0](#), except where otherwise stated

[© Crown copyright](#)

# **APPENDIX D**

**EXETER CITY COUNCIL APPROVED VEHICLE INSPECTION REPORT**

**Customer Details**

Report Date: 04/03/26

Report No: 10513



**Customer's contact details**

Home:

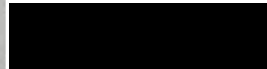

**VEHICLE DETAILS**

Make Peugeot

Registration Number



Model Partner Horizon Rel/Blue Hd S/S  
Tepee Allure

Colour Grey / Red / Black

Vehicle Identity Number (VIN)



VIN Checked and confirmed  
on vehicle  
Yes X No

V5/Registration document  
available and checked

MOT Certificate available and  
checked

Yes

Mileage reading In 174203  
(Not guaranteed) Out 174206

MOT Expiry Date

07/03/27

Vehicle Excise Licence Expiry

01/08/26

Date of inspection 04/03/26

Time of inspection

09:30

Location of vehicle



Lighting

Good

Weather.

Good

Ramp available.

(See notes)

Yes  No

**SECURITY CHECK**

The vehicle identification number on this vehicle was checked and found to be **consistent** with the manufacturer's format.

**SUMMARY REPORT**

READY FOR USE – No faults found, suitable for immediate use

X **ADVISABLE REPAIRS ONLY** – Suitable for immediate use but advisable repairs should be planned for

**ESSENTIAL REPAIRS REQUIRED** – Not suitable unless all essential repairs are undertaken and advisable repairs, if any are planned for

**UNSATISFACTORY** – Vehicle has significant deficiencies, which are judged to be impractical or uneconomical to repair to a satisfactory standard.

Please read all pages of this report

**KEY:**  
 S satisfactory  
 R repainted  
 = scratch  
 X dent  
 O corrosion  
 C chip / rust  
 P previous repairs  
 W Wrap Missing

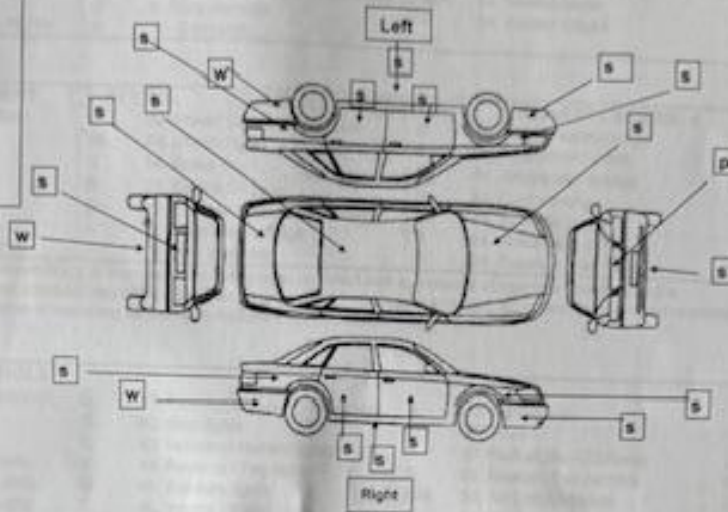

Minor blemishes, which are acceptable fair wear and tear for the vehicle's age, recorded mileage and type, are not recorded and you should satisfy yourself in this regard.

EVIDENCE OF BODYWORK REPAIRS      Yes X      No

BODYWORK CLEAN                              Yes X      No (See Notes)

**KEY FOR POINTS ON FOLLOWING PAGES**

S      Satisfactory for age and recorded mileage  
 -      Could not be checked  
 x      Essential repair requiring immediate attention  
 A      Advisable repair should be considered prior to purchase  
 N/A    Not applicable  
 Y      Yes  
 N      No  
 Please note: Right = Off side (O/S) and Left = Near side (N/S) as viewed from the driver's seat.

Report No. 10513

BODY EXTERIOR			
1. Panel Condition / alignment	S	6. Door locks - operation	S
2. Paintwork	S	7. Fuel filler cover and cap	S
3. Exterior trim /grille	S	8. Soft top / Hard top (operation)	N/A
4. Glass	S	9. Body damage	S
5. Bumpers / No plates - Ft / Rr	S	10. Corrosion	No
		11. Mud flaps	S
		12. Body panels	S
		13. Bonnet catch	S
		14. Bonnet hinges	S

ENGINE COMPARTMENT	<input type="checkbox"/> PETROL	<input checked="" type="checkbox"/> DIESEL	<input type="checkbox"/> HYBRID	No. of CYLINDERS: 4
15. Coolant Level / Condition	S	22. Power Steering - oil level	S	29. Turbo / supercharger
16. Coolant leaks	No	23. Clutch Fluid	S	30. Fuel pump / pipes
17. Antifreeze *	S	24. Braks Fluid	S	31. Accelerator linkage
18. Radiator / Cap	S	25. Engine Oil level	S	32. Cold starting
19. Hoses / Pipes	S	26. External leaks (upper engine)	S	33. Fast idle (cold)
20. Drive Belts	-	27. Engine mountings	S	34. Noise level (cold)
21. Water Pump (Not visible)	-	28. Fuel Injection	S	35. Excess fumes / smoke
				No

Note - To ensure future serviceability, it is important that the engine camshaft belt is replaced at intervals specified by the manufacturer. It is in your best interests you ensure that this is carried out. \* Antifreeze only has a 2/3 year life span and requires its strength adjusting after this time or replacing as per manufacturers specifications.

ELECTRICAL / CONTROLS			
36. Starting system / Ignition lock	S	41. Rear lights & No. plate lights	S
37. Battery condition	S	42. Stop lights	S
38. Battery voltages	S	43. Indicator / Hazard lights	S
- Normal 12.17 volts	S	44. Reverse / Fog lights	S
- Starting 10.30 volts	S	45. Auxiliary lights	N/A
- Charging 14.45 volts	S	46. Interior / Panel lights	S
39. Headlights	S	47. Mirrors (electric)	S
40. Sidelights / running lights	S	48. Controls / Switches	S
		49. Instruments	S
		50. Horn	S
		51. Radio/Cass/CD/Aerial	S
		52. Heater / Fan controls	S
		53. Air Con operation	S
		54. Windows / Sun roof	S
		55. Wipers / Washers	S
		56. Headlamp wash / wipe	S

Note - We are unable to verify dash panel light and switch back lighting operation due to the daylight conditions. Please note that switching them "on or off" only assesses electrical components. Accuracy of instruments cannot be assessed.

INTERIOR / LUGGAGE COMPARTMENT		NUMBER OF SEATS: 5	
57. Steering Wheel / Adjustment	S	64. Door seats / hinges	S
58. Seat upholstery	S	65. Interior sills	S
59. Seat adjustment	S	66. Headlining / visors	S
60. Seatbelts	S	67. Sun roof	N/A
61. Carpets / Mats	S	68. Dash panel (condition)	S
62. Door trim panels	S	69. Cigarette lighter	N/A
63. Door fittings / operation	S	70. Mirrors (internal)	S
		71. Rear parcel shelf / load cover	-
		72. Boot / tailgate lock	S
		73. Luggage area trim con	S
		74. Illumination light	S
		75. Tool kit	S
		76. Hard / Soft top (condition)	N/A
		77. Tonneau cover	N/A

FRONT SUSPENSION / STEERING / UNDER FRAME			
78. Engine underside leakage	No	83. Wheel hubs / bearings	S
79. Steering joints/ ball joints	S	84. Springs/suspension units	S
80. Steering rack / box	S	85. Pipes / hoses	S
81. Chassis members	S	86. Dampers (condition / leaks)	S
82. Power steering (operation)	S	87. Gaiters	S
		88. Sub-frames mountings	S
		89. Suspension arms / mountings	S
		90. Tie bars / anti roll bars	S
		91. Corrosion protection	Yes
		92. Corrosion - floor/chassis	No

REAR SUSPENSION / UNDER FRAME			
93. Springs/suspension bars	S	97. Location rods/fixings	N/A
94. Anti roll bar	S	98. Bump stops/gaiters	S
95. Dampers/bushes	S	99. Wheel hubs/bearings	S
96. Suspension arms/fixings	S	100. Pipes/hoses	S
		101. Sub-frames/ mountings	S
		102. Chassis members	S
		103. Corrosion protection	Yes
		104. Corrosion - floor/chassis	No

CLUTCH / TRANSMISSION	<input type="checkbox"/> MANUAL	<input checked="" type="checkbox"/> AUTOMATIC
105. Fluid / oil leaks	No	109. Casings
106. Cables / adjustments	N/A	110. Mountings
107. Hydraulic system	S	111. Drive shaft assembly
108. Linkage (wear)	S	112. Universal / sliding joints
		113. Backlash
		114. Gaiters
		115. Propshaft(s) / fittings
		116. Bearings / supports

**EXHAUST SYSTEM**

117. Manifold	S	120. Silencer(s)	S	123. System condition	S
118. Pipes	S	121. Heat shields / mountings	S		
119. Catalytic converter (s)	S	122. Joints / couplings	S		

**FUEL SYSTEM**

124. Tank	S	126. Fuel lines	S	128. Evidence of leaks	No
125. Tank fixings	S	127. Breather pipes	S		

**BRAKES**

129. Master cylinder security	S	132. Flexible hoses	S	135. Handbrake op / adjustment	S
130. Fluid leaks	No	133. Pipes / connections	S	136. Handbrake mechanism	S
131. Servo / power system	S	134. Discs / pads (if visible)	S	137. Pedal and pad / linkage	S

Note - If the vehicle is fitted with brake drums the internal parts including linings are not visible. Brake fluid should be replaced at the manufacturers specified intervals.

**WHEELS AND TYRES Type: Steel**

It is recommended tyres be replaced when the tread depth reaches 2mm. If uneven tyre wear is noted, this may indicate incorrect geometry, which can result in excessive and rapid tyre wear. A full steering and geometry check is recommended.

138. Wheel Rims	S				
139. Wheel Trims	S				
<b>Tyres</b>	<b>Make</b>	<b>Size</b>	<b>Type / Construction</b>	<b>Min tread depth</b>	
140. Front RH	Dynamo	205/65/15	Radial	6.5mm	S
141. Front LH	Dynamo	205/65/15	Radial	6.5mm	S
142. Rear LH	Dynamo	205/65/15	Radial	2.0mm	A
143. Rear RH	Dynamo	205/65/15	Radial	2.0mm	A
144. Spare	No Spare wheel of Emergency inflation device				A

**145. ROAD TEST**

The road test has been undertaken within the speed limits and prevailing traffic conditions in the locality of the inspection. If a road test has not been carried out, please refer to the engineer's comments page.

\*If the vehicle is fitted with 4wd transmission then the systems have been checked for security, leakage and excessive noise. However, within the limitations of the road test the full functionality could not be checked.

<b>Test Distance</b>	<b>3 Miles</b>	<b>Speed achieved up to 40 MPH</b>			
146. Final drive operation / Noise level	S	153. Instrument /controls function	No	160. Road holding / stability	S
147. Gearbox operation / Noise level	S	154. Steering wheel alignment	S	161. General steering / handling	S
148. Engine performance	S	155. 4WD operation *	N/A	162. Footbrake operation	S
149. Engine noise	S	156. Clutch operation **	S	163. Hand/park brake operation	S
150. Excess stroke	No	157. Cooling fan operation	S	164. Suspension noise	No
151. Overheating evidence	No	158. Steering effort	S	165. Warning lights	S
152. Auto changes / kick-down	N/A	159. Hot restarting	S	166. Cruise control	S

\*\* It should be carefully noted that the life expectancy of clutches is uncertain and difficult to predict, being dependant on owners driving style, vehicle operation and terrain. The fact that the clutch has not been identified as faulty/slipping/juddering/noisy on the report does not and should not be taken to imply that the clutch assembly will have a continuing life expectancy from the time of our check. They can begin to slip at any time.

**FINAL CHECK**

167. Oil leaks	No	168. Coolant leaks	No	169. Uneven tyre wear	No
----------------	----	--------------------	----	-----------------------	----

Report No. 10513

### Vehicle documents and inspection environment notes.

Engineer indicates with "X" as applicable.

#### Registration Document (V5):

- No registration document was seen with the vehicle and you are advised to satisfy yourself that the vehicle identification number and engine number (where quoted) correspond to those shown on this report. Warning: **DO NOT BUY ANY VEHICLE WITHOUT A V5.**
- The V5/Registration Document shows \_\_\_\_\_ previous keeper(s), the last change of Keeper on \_\_\_\_\_

#### Security:

- The Master Key was not available. Please ensure this is supplied if the vehicle is purchased.
- The engineer recommends that relevant spare and service keys be obtained prior to purchase.
- Obtain hand books and radio codes for vehicle prior to purchase as these were not seen in the vehicle.

#### MOT:

- As only a small amount of time is left on the MOT Certificate (less than 3 months) the engineer recommends a full year's MOT be obtained prior to purchase.
- A 12 Month MOT Certificate has been seen with the vehicle.

#### Servicing:

- The service history seen, indicated that the last recorded service was carried out at \_\_\_\_\_ miles. No immediate servicing is necessary. Next service is due as per manufacturer's recommendations or as per the Vehicles Service Indicator.
- The service history seen, indicated that the last recorded service was carried out on \_\_\_\_\_ miles. Therefore the engineer would suggest a full service and brake inspection to the manufacturer recommendations prior to purchase, which may reveal further defects not apparent at this examination.
- No service documentation seen with this vehicle and therefore the engineer would recommend a full service and brake inspection to the manufacturer's recommendations prior to purchase, which may reveal further defects not apparent at this examination.

#### Inspection conditions notes:

- No vehicle hoist/ramp was available. A large trolley jack and stands were used in order to carry out underside checks. This limits the view of the underside. Some areas could not be fully seen. There may be further defects, which may be visible given clear access and view.
- The body/paintwork was wet/dirty/dusty this severely restricts inspection of the paintwork. Please note that there may be other defects present, which were not visible due to the obscured paintwork, but which may become visible once dry and clean.

Report No: 10513

## Engineers Comments

The vehicle is considered overall to be a fair and reasonable example of the type, being in a generally reasonable condition and generally considered to be consistent with the type for the age and indicated recorded mileage in most areas.

The items listed as "could not be checked" (---) normally indicate items were obscured by covers/shields or other equipment.

The Water pump – Engine drive belt/chain - these items could not been fully examined, as covers, trims and other equipment obscure them.

The cooling system was pressure tested to 0.7 bars, no pressure loss was noted on the system or pressure cap. The antifreeze concentration was acceptable, but has deteriorated from its original strength and at the next routine service may need to be refreshed/replaced. It is advised that the coolant strength be checked again at the next routine service. Antifreeze only has a 2/3-year life and requires its strength adjusting after this time or replacing as per manufacturer's specifications.

The vehicle is fitted with vented front brake disc and pads, supported at the rear by a single arrangement. Although the visible brakes only show some signs of general serviceable wear, some deterioration is noted, which will need attention in the near future. It is strongly advised to remove all road wheels and examine the inner brake components, which are obscured on this vehicle prior to purchase, replacing any worn or badly corroded parts. It is probable that the front brakes at least, will need to be replaced at the next routine service.

The steering & suspension has been assessed to MOT standard. This allows for a degree of wear and deterioration of components without rendering them unserviceable. The extent of wear is not considered excessive at this juncture and unlikely to attract MOT failure.

The road test distance and or top speed was limited due to the general area/inspection location, and/or traffic levels and/or adverse weather conditions and/or lack of fuel when the vehicle was tested and driven. Comment cannot be made in these instances in relation to possible "high speed" or "sustained speed," related driving defects, which may become apparent at a later stage after any purchase due to these limiting conditions.

**Essential Repairs**

It is strongly advised that the essential defects are investigated and rectified prior to purchase.

**Comment**

**Additional Comments**

NONE.

Report No. 10513

### Advisable Repairs

Please note that the advisable items may prove costly to repair and must be considered.

Item	Comment
142	NSR tyre close to legal limit.
143	OSR tyre close to legal limit.
144	No Spare wheel or Emergency inflation device.

Report No. 10513

#### PLEASE READ CAREFULLY

- You are strongly advised to discuss the findings of this report with the vendor prior to making your decision to purchase the vehicle.
- Essential repairs should be investigated and rectified prior to purchase. These may be costly.
- Advisable repairs may prove costly to repair and must be considered prior to purchase.

Engineers Name  
Qualifications



Date 04/03/26

This page is intentionally left blank

# **APPENDIX E**







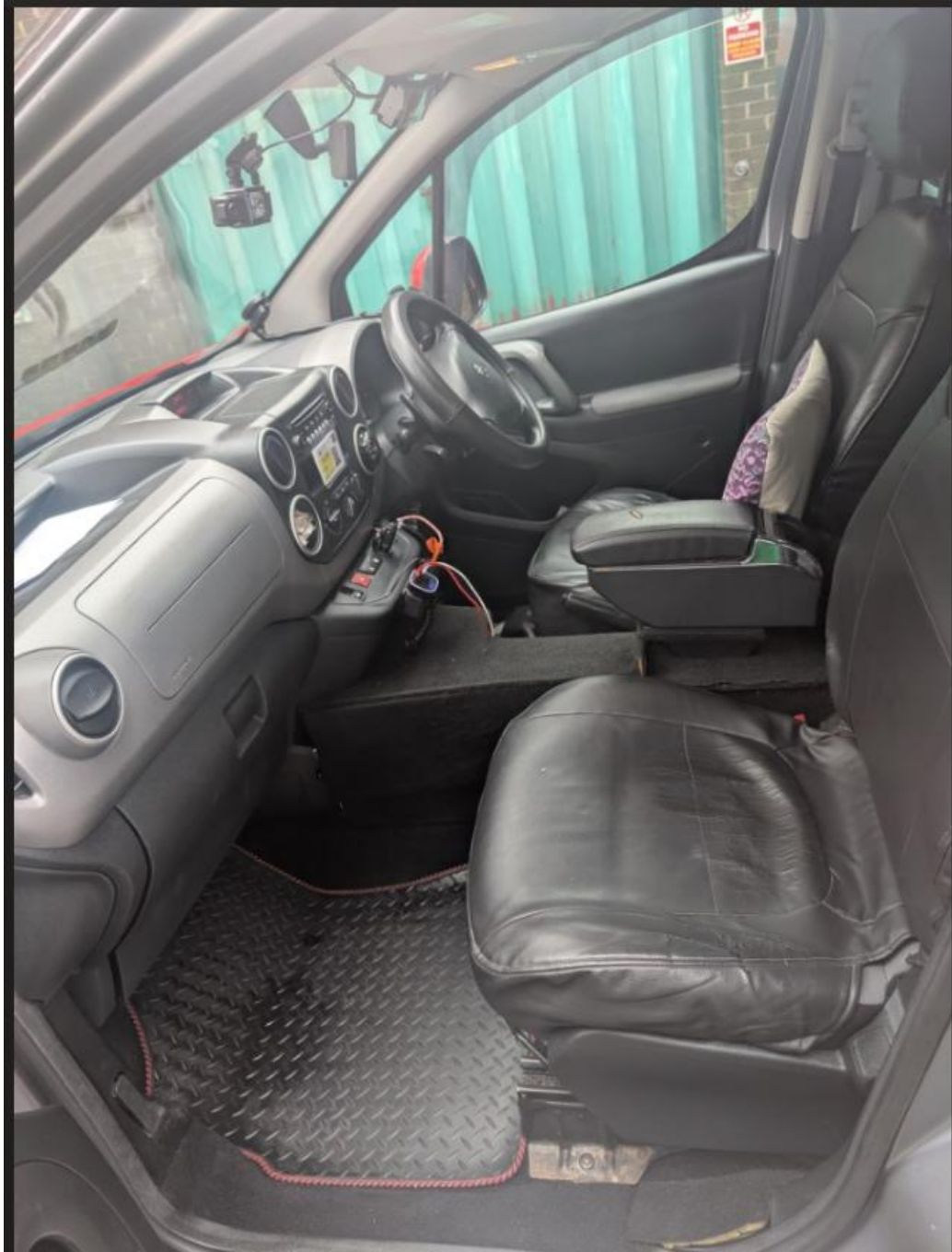





This page is intentionally left blank

## REPORT TO LICENSING SUB COMMITTEE

<b>Date of Hearing:</b>	<b>15.04.2026</b>
<b>Report of:</b>	<b>Geraldine Pendlington Licensing Officer</b>
<b>Decision Required:</b>	<b>RENEWAL of a licence relating to a Private Hire vehicle over 10 years old.</b>
<b>Legislation:</b>	<b>Local Government (Miscellaneous Provisions) Act 1976</b>
<b>Applicant:</b>	<b>[REDACTED]</b>

### 1. What is the report about?

- 1.1 An application is attached at Appendix A that has been received from the Applicant, a licensed private hire operator and driver seeking permission for the renewal of a private hire vehicle licence for a vehicle which is over 10 years old. The vehicle was 10 years old on the 29 March 2026. This is a matter that cannot be dealt with under the delegated powers.

### 2. Background:

- 2.1 The vehicle that is being presented for licensing as a private hire vehicle is a 6 passenger, Seat Alhambra, registration number WF16 EHR, with a date of first registration of 29 March 2016. A copy of the vehicle registration document is attached at Appendix D.

### 3. Report Details:

- 3.1 The vehicle has a current MOT certificate dated 23 February 2026 and expires 22 February 2027. The mileage recorded at the MOT inspection was 135,999 miles. The MOT certificate and MOT history are included at Appendix C and vehicle insurance is included at Appendix B. In addition to the MOT certificate there is an independent mechanical inspection report, which has been submitted, this is dated 06 March 2026 and is attached at Appendix E. Advisory repairs were indicated on the vehicle inspection report and evidence of this completed work is attached at Appendix E. Photos of the vehicle are attached at Appendix F. Upon inspection by a Council Officer the vehicle was found to be in good condition for the age. The vehicle was first plated by Exeter City Council on 07 April 2016 and has been continuously licenced since that date.
- 3.2 The Licensing Sub-Committee must have regard to the Council's Practices and Procedures for the control of Hackney Carriage and Private Hire Vehicles, Drivers and Operators and the Code of Conduct for Licensed Drivers ('Taxi Policy').
- 3.3 Vehicles presented for renewal that are more 10 years old, shall not be granted. However, the Applicant will be given the right to apply for the application to be considered by a licensing sub-committee if they feel that their particular circumstances justify a deviation from the existing Policies.

#### **4. What are the legal aspects?**

4.1 Section 48(1) of the Local Government (Miscellaneous Provisions) Act 1976 ('the Act') states that a district council may on receipt of an application from the proprietor of any vehicle for the grant in respect of such vehicle of a licence to use the vehicle as a private hire vehicle, grant in respect thereof a vehicle licence:

Provided that a district council shall not grant such a licence unless they are satisfied-

a) that the vehicle is-

- i) suitable in type, size and design for use as a private hire vehicle;
- ii) not of such design and appearance as to lead any person to believe that the vehicle is a hackney carriage;
- iii) in a suitable mechanical condition;
- iv) safe; and
- v) comfortable;

b) that there is in force in relation to the use of the vehicle a policy of insurance or such security as complies with the requirements of Part VI of the Road Traffic Act 1988, and shall not refuse such a licence for the purpose of limiting the number of vehicles in respect of which such licence are granted by the council.

4.2 Under Section 48(4)(c) of the Act the Licensing Sub-Committee may grant a licence for a maximum period of 12 months.

4.3 Any person aggrieved by a refusal of the Licensing Sub-Committee to grant a vehicle licence under Section 48 of the Act may appeal to the Magistrates Court within 21 days of receiving written notice of the refusal.

#### **5. Recommendations:**

5.1 The Licensing Sub-Committee are asked to determine the application having regard to current policy.

#### **Service Lead – Environment and Waste**

Author: Geraldine Pendlington

#### **Local Government (Access to Information) Act 1972 (as amended)**

Background papers used in compiling this report:-  
None

Contact for enquires:  
Democratic Services (Committees)  
Room 4.36  
01392 265275

# APPENDIX A

Plate Number...P162.....



**Application for the renewal of a Hackney Carriage or a Private Hire Vehicle Licence**

**NAME OF PROPRIETOR**

We ..... [redacted] .....

Address: ..... [redacted] .....

Telephone No. .... [redacted] .....

e-mail address..... [redacted] .....

Any other person who is a proprietor of the vehicle or who is concerned either solely or in partnership with any other person in the keeping, employing or letting of hire of the vehicle.

<u>Name</u>	<u>Address</u>
[redacted] .....	[redacted] .....
[redacted] .....	[redacted] .....
.....	.....

Hereby apply for a Licence for the undermentioned motor vehicle to be used as a \*Hackney Carriage / \*Private Hire Vehicle within the City of Exeter and I hereby declare that all particulars entered on the form are true and correct to the best of my knowledge and belief. (\* Delete which does not apply)

Make of Vehicle: SEAT Alhambra..... Number of Passengers.....6.....

Registration No. WF16EHR..... Date of First Registration of Vehicle 29/03/2016

Vehicle Registration Document No.  
(at bottom right of document).....40086753125.....

Details of Current Vehicle Insurance ERS Insurance Policy Number 50865907.....

Date of Issue .....01/01/2026.....

Where will the vehicle be kept when not in use? (Address) ...10 Brooke Avenue Exeter EX2 6DA

In respect of Private Hire Vehicles, by which operator, and from what address will the Private Hire Vehicle be operated?

Name of Operator: ..... [redacted] .....

Address: ..... [redacted] .....

**When an application involves the substitution or exchange of an existing vehicle by a new one, please answer the following questions:**

1. Will the replaced vehicle continue to be used as a Licensed Private Hire/Hackney Carriage vehicle? YES/NO
2. If No, please specify reason (i.e. private use, taken off road etc).....
3. If continuing to be used as a Licensed vehicle, please give name and address of the new owner .....
4. Make and Registration of existing Licensed vehicle .....
5. Licence and Plate No: ..... Date of Expiry .....

I understand that omissions or incorrect statements will render the Licence if granted, liable to suspension or revocation and render me liable to prosecution.

I have been given a copy of the conditions relating to this Licence.

Signed .....  .....

Dated ..... MARCH 2026 .....

Any changes in the circumstances which might render any of the above information incorrect must be immediately reported to the Office of the Assistant Director Environment, Exeter City Council, Paris Street, Exeter, EX1 1RQ

**NB INFORMATION DISCLOSED ON THIS FORM MAY BE REVEALED TO OTHER AGENCIES AND BODIES FOR THE SOLE PURPOSE OF PREVENTING OR DETECTING CRIMES.**

**Private Hire Vehicle Renewal Procedure:**

Licenses for Private Hire vehicles are issued for a maximum of 12 months at any one time. Vehicles presented for renewal that are less than 8 years old can be renewed by Licensing Officers under delegated powers.

Vehicles presented for renewal that are between 8 and 9 years old can be renewed by Licensing Officers under delegated powers provided that the vehicle is presented for inspection in a satisfactory condition, and a comprehensive report provided into the mechanical fitness of the vehicle has been undertaken by the AA, RAC, or DEKRA, or any other approved engineer, and any essential works identified have been carried out and evidence provided to establish this. If Officers are in doubt as to the fitness or suitability of a vehicle to carry on as a licenced vehicle then they shall refer the application to the Sub-committee for determination.

Vehicles presented for renewal that are between 9 and 10 years old will be referred to the licensing sub-committee for determination. Applicants will be advised to provide a comprehensive report into the mechanical fitness of the vehicle as outlined above.

*Vehicles presented for renewal that are more 10 years old, shall not be granted. However the applicant will be given the right to apply for the application to be considered by a licensing sub-committee if they feel that their particular circumstances justify a deviation from the existing Policies.*

**OFFICE USE ONLY**

Fee paid ..... Date ..... Receipt No .....

**INSPECTION OF:**

- |     |                                 |              |        |
|-----|---------------------------------|--------------|--------|
| (1) | Insurance                       | Satisfactory | YES/NO |
| (2) | Fire Extinguisher/First Aid Kit | Satisfactory | YES/NO |
| (3) | Cleanliness                     | Satisfactory | YES/NO |
| (4) | Advertising Signs               | Satisfactory | YES/NO |
| (5) | Meter                           | Satisfactory | YES/NO |
| (6) | Plate Fixing                    | Satisfactory | YES/NO |
| (7) | Tariff                          | Satisfactory | YES/NO |
| (8) | Bus Lane stickers               | Satisfactory | YES/NO |

Licence to be issued : YES / NO

Signed..... Date.....

Licensing Officer

Notes .....

# APPENDIX B

# Certificate of Motor Insurance



Policy number [REDACTED]

**1. Description of vehicle(s)**

Any motor vehicle the property of, or on hire or loan or lease to the policyholder.

**2. Name of policyholder**

[REDACTED]

**3. Effective date and time of the commencement of insurance for the purpose of the relevant law**

01 January 2026 00:01

**4. Date of expiry of insurance**

31 December 2026

**5. Persons or classes of persons entitled to drive**

Any person who is driving on the order or with the permission of the policyholder.

Providing that the person driving has a licence to drive the vehicle or has held and is not disqualified from or prohibited by law from holding or obtaining such a licence.

**6. Limitations as to use**

- A. Use for the business of the policyholder for private hire and the carriage of passengers and goods for hire or reward.
- B. Use for social, domestic and pleasure purposes.

**Unless specified under section 6 of this certificate of insurance, this policy does not cover:** use for hiring, the letting on hire, the carriage of passengers and goods for hire or reward, racing, pacemaking, use in any contest, reliability or speed trial or the use for any purpose in connection with the motor trade.

I hereby certify that the policy to which this certificate of insurance relates satisfies the requirements of the relevant law applicable in Great Britain, Northern Ireland, Isle of Man and the Islands of Guernsey, Jersey and Alderney.

For and on behalf of the Underwriter subscribing ERS, 30 Fenchurch Street, London EC3M 3BD

Authorised Insurer

A handwritten signature in black ink, appearing to read 'Scott Tillbrook'.

Scott Tillbrook  
Active Underwriter

**Advice to third parties - Nothing contained in this certificate of insurance affects your rights as a third party to make a claim.**

Note: For full details of the insurance cover reference should be made to the policy document, which can be obtained from your broker or via our website at [www.ers.com](http://www.ers.com)



## This page forms part of your certificate of insurance

### European cover

This certificate of motor insurance is evidence that this insurance meets the compulsory motor insurance requirements of all member countries of the European Union and Andorra, Bosnia and Herzegovina, Iceland, Montenegro, Norway, Serbia and Switzerland (including Liechtenstein).

Ce certificat d'assurance automobile est une preuve que cette assurance est conforme aux exigences de l'assurance automobile obligatoire de tous les pays membres de l'Union européenne et l'Andorre, la Bosnie-Herzégovine, l'Islande, du Monténégro, la Norvège, la Serbie et la Suisse (y compris le Liechtenstein).

Dieses Zertifikat der Kfz-Versicherung ist ein Beweis, dass diese Versicherung die Kfz Haftpflichtversicherungsanforderungen von allen Mitgliedsländern der Europäischen Union und Andorra, Bosnien und Herzegowina, Island, Montenegro, Norwegen, Serbien und der Schweiz (einschließlich Liechtenstein) erfüllt.

Este certificado de seguro de automóviles es evidencia de que este seguro cumpla con los requisitos de seguro obligatorio de automóviles de todos los países miembros de la Unión Europea y Andorra, Bosnia y Herzegovina, Islandia, Montenegro, Noruega, Serbia y Suiza (incluido Liechtenstein).

Questo certificato di assicurazione auto è la prova che questa assicurazione soddisfa i requisiti di assicurazione obbligatoria degli autoveicoli di tutti i paesi membri dell'Unione europea e Andorra, Bosnia ed Erzegovina, Islanda, Montenegro, Norvegia, Serbia e Svizzera (compreso il Liechtenstein).



This page is intentionally left blank

# APPENDIX C

# MOT test certificate



Driver & Vehicle  
Standards  
Agency

① Vehicle identification number

[REDACTED]

②a) Registration number

②b) Country of registration

**GB**

Make and model

**SEAT ALHAMBRA**

⑤ Vehicle category

④ Mileage

Mileage history

**135,999 miles**

**126,914 miles**

06.02.2025

**113,622 miles**

13.02.2024

**103,546 miles**

15.02.2023

⑦ **Pass**

⑥a) Date of the test

**23.02.2026**

⑥b) Expiry date

**22.02.2027**

To preserve the anniversary of the expiry date, the earliest you can present your vehicle for test is 23.01.2027.

③a) Location of the test

[REDACTED]

③b) Testing organisation and inspector name

[REDACTED]

MOT test number

[REDACTED]

Check that this document is genuine by visiting [www.gov.uk/check-mot-history](http://www.gov.uk/check-mot-history)

If any of the details are not correct, please contact DVSA by email at [enquiries@dvsa.gov.uk](mailto:enquiries@dvsa.gov.uk) or by telephone on 0300 1239000.

Receive a free annual MOT reminder by subscribing at [www.gov.uk/mot-reminder](http://www.gov.uk/mot-reminder) or by telephone on 0300 1239000.

Issuer signature



# SEAT ALHAMBRA

[Check another vehicle](#)

Colour  
**Silver**

Fuel type  
**Diesel**

Date registered  
**29 March 2016**

MOT valid until  
**22 February 2027**

[Get an MOT reminder](#) by email or text.

[Download test certificates](#)

You can [get information corrected on your MOT history](#) (such as mileage or vehicle details) if it's wrong.

[Hide all sections](#)

## MOT history

Check mileage recorded at test, expiry date, and test outcome

[Hide](#)

Date tested  
**23 February 2026**

Mileage  
**135,999 miles**

MOT test number

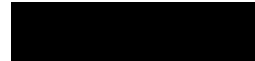

**PASS**

Test location

[View test location](#)

Expiry date  
**22 February 2027**

Date tested  
**20 February 2026**

Mileage  
**135,998 miles**

MOT test number



**FAIL**

Test location

[View test location](#)

Do not drive until repaired (dangerous defects):

- **Offside Front Tyre tread pattern not visible over the whole tread area when minimum depth required is 1.0mm (5.2.3 (e))**

Repair immediately (major defects):

- **Nearside Front Windscreen wiper does not clear the windscreen effectively (3.4 (b) (ii))**
- **Offside Front Windscreen wiper does not clear the windscreen effectively (3.4 (b) (ii))**

Date tested  
**6 February 2025**

**PASS**

Mileage  
**126,914 miles**

Test location  
[▶ View test location](#)

MOT test number

Expiry date  
**22 February 2026**

Date tested  
**13 February 2024**

**PASS**

Mileage  
**113,622 miles**

Test location  
[▶ View test location](#)

MOT test number

Expiry date  
**22 February 2025**

Date tested  
**15 February 2023**

**PASS**

Mileage  
**103,546 miles**

Test location  
[▶ View test location](#)

MOT test number

Expiry date  
**22 February 2024**

Date tested  
**15 February 2023**

**FAIL**

Mileage  
**103,545 miles**

Test location  
[▶ View test location](#)

MOT test number

Do not drive until repaired (dangerous defects):

- **Offside Front Tyre tread depth below requirements of 1.6mm (5.2.3 (e))**
- **Offside Rear Tyre tread depth below requirements of 1.6mm (5.2.3 (e))**

Date tested  
**23 February 2022**

**PASS**

Mileage  
**93,096 miles**

Test location  
[▶ View test location](#)

MOT test number

Expiry date  
**22 February 2023**

Date tested  
**22 February 2022**

**FAIL**

Mileage  
**93,095 miles**

Test location  
[▶ View test location](#)

MOT test number

Do not drive until repaired (dangerous defects):

- **Nearside Rear Tyre tread depth below requirements of 1.6mm (5.2.3 (e))**

Date tested  
16 February 2021

**PASS**

Mileage  
76,855 miles

Test location

▶ [View test location](#)

MOT test number

Expiry date  
20 February 2022

Monitor and repair if necessary (advisories):

- **Front Brake disc worn, but not excessively (1.1.14 (a) (i))**
- **Front Brake pad(s) wearing thin (1.1.13 (a) (ii))**
- **Nearside Rear Nail in tyre**

▶ [What are advisories?](#)

Date tested  
21 February 2020

**PASS**

Mileage  
61,186 miles

Test location

▶ [View test location](#)

MOT test number

Expiry date  
20 February 2021

Date tested  
18 February 2020

**FAIL**

Mileage  
61,183 miles

Test location

▶ [View test location](#)

MOT test number

Repair immediately (major defects):

- **Fuel tank leaking (6.1.3 (b) (i))**
- **Nearside Front Lower Suspension arm pin or bush excessively worn (5.3.4 (a) (i))**
- **Offside Front Lower Suspension arm pin or bush excessively worn (5.3.4 (a) (i))**

Date tested  
20 March 2019

**PASS**

Mileage  
48,409 miles

Test location

▶ [View test location](#)

MOT test number

Expiry date  
30 March 2020

Monitor and repair if necessary (advisories):

- **Nearside Front Suspension arm pin or bush worn but not resulting in excessive movement (5.3.4 (a) (i))**
- **Offside Front Suspension arm pin or bush worn but not resulting in excessive movement (5.3.4 (a) (i))**

Date tested  
20 March 2019

**FAIL**

Mileage  
48,409 miles

MOT test number

Test location

▶ [View test location](#)

Repair immediately (major defects):

- **Offside Rear Tyre has a cut in excess of the requirements deep enough to reach the ply or cords (5.2.3 (d) (i))**
- **Front Windscreen wiper does not clear the windscreen effectively (3.4 (b) (ii))**

Monitor and repair if necessary (advisories):

- **Nearside Front Suspension arm pin or bush worn but not resulting in excessive movement (5.3.4 (a) (i))**
- **Offside Front Suspension arm pin or bush worn but not resulting in excessive movement (5.3.4 (a) (i))**

The MOT test changed on 20 May 2018

Defects are now categorised according to their severity - dangerous, major, and minor. [Find out more.](#)

Date tested  
19 March 2018

**PASS**

Mileage  
31,322 miles

MOT test number

Test location

▶ [View test location](#)

Expiry date

30 March 2019

Advisory notice item(s)

- **Front brake disc worn, pitted or scored, but not seriously weakened (3.5.1i)**
- **Front Brake pad(s) wearing thin (3.5.1g)**

Date tested  
31 March 2017

**PASS**

Mileage  
15,755 miles

MOT test number

Test location

▶ [View test location](#)

Expiry date

30 March 2018

Advisory notice item(s)

- **Offside Front Tyre worn close to the legal limit (4.1.E.1)**
- **Offside Rear Nail in tyre**

# APPENDIX D

# Vehicle details

Official use only

A Registration number [REDACTED]

[A.1] R

B: Date of first registration 29 03 2016  
 [B.1]: Date of first registration in the UK 29 03 2016  
 D.1: Make SEAT  
 D.2: Type 7N  
 Variant DFMAX0AF  
 Version FD6FD62E0327MMN7VR2SE64

E: VIN/Chassis/Frame No [REDACTED]  
 P.5: Engine number DFMAU005415  
 F.1: Max. permissible mass (exc. m/c) 2550  
 G: Mass in service 1845  
 Q: Power/Weight ratio (kW/kg) (only for motorcycles)  
 R: Colour SILVER

O: Technical permissible maximum towable mass of trailer  
 O.1: braked (kg) 2200  
 O.2: unbraked (kg) 750  
 U: Sound level  
 U.1: stationary (dB(A)) 72  
 U.2: engine speed (min-1) 2375  
 U.3: drive-by (dB(A)) 70  
 V: Exhaust Emissions  
 V.1: CO (g/km or g/kWh) 0.062  
 V.2: HC (g/km or g/kWh)  
 V.3: NOx (g/km or g/kWh) 0.064  
 V.4: HC+NOx (g/km)  
 V.5: particulates (g/km or g/kWh)  
 Automated vehicle (AV)

Euro status  
 Real driving emissions  
 D.3: Model ALHAMBRA SE LUX TDI S-A  
 D.5: Body type MPV  
 [X]: Taxation class DIESEL CAR  
 [D.6]: Suspension type  
 [Y]: Revenue weight 2550 KG GROSS  
 P.1: Cylinder capacity (cc) 1968 CC  
 V.7: CO<sub>2</sub> (g/km) 139 G/KM  
 P.3: Type of fuel HEAVY OIL  
 S.1: Number of seats, including driver 7  
 S.2: Number of standing places (where appropriate)  
 [D.4]: Wheelplan 2-AXLE-RIGID BODY  
 J: Vehicle category M1  
 K: Type approval number e1\*2007/46\*0402\*12  
 P.2: Max. net power (kW) 135

## 1 Change my vehicle details – Only fill in details to be corrected or changed

H

By submitting this form you are declaring that the information provided is correct. If you have made changes to your vehicle or if the information above is incorrect, you must

tell us by filling in the relevant boxes below and send whole V5C to DVLA, Swansea, SA99 1BA. Use black ink and CAPITALS.

Registration number [REDACTED] R

Document reference number 4008 675 3125

Wheelplan or Body type:

VIN, Chassis or Frame number:

New revenue weight: Date of change: Cylinder capacity (cc):

No. of seats inc. driver: No. of standing places: Type of fuel:

Engine number:

New colour: Date of change: CLR

Tax class: Y

For information on how to change your tax class go to [gov.uk/change-vehicle-tax-class](http://gov.uk/change-vehicle-tax-class)

## 2 Selling or transferring my vehicle to a new keeper (not a trader)

W

By submitting this form you are declaring that the information provided is correct. You must tell us immediately if you have sold or transferred your vehicle. It's quick and simple to tell us online. If you don't receive an acknowledgment or tax refund, if applicable, go to [gov.uk/contact-the-dvla](http://gov.uk/contact-the-dvla) as you may still be liable. If you want to keep the registration number you must do this before you sell or transfer it. To tell us go to: [gov.uk/keep-registration-number](http://gov.uk/keep-registration-number)

You can use this form to tell us if you have:

- Sold your vehicle privately – fill in the boxes below and the date of sale on section 6 over the page. Use black ink and CAPITALS. Tear off section 6 (green slip) give it to the new keeper. Return the rest of the V5C to DVLA, Swansea, SA99 1BA.
- Sold, transferred or part exchanged your vehicle to a motor trader – go to section 4 (yellow section) on the next page.

Registration number [REDACTED] R

Document reference number 4008 675 3125

Title: Mr:  Mrs:  Miss:

Or other title, or business or company name:

New keeper's first and middle names written in full:

Surname:

DVLA fleet number for companies only: Date of birth: (optional)

Current UK address (house number, street name, town or city):  
 Foreign address? For information go to: [gov.uk/taking-vehicles-out-of-uk](http://gov.uk/taking-vehicles-out-of-uk)

Postcode:

Date of sale: (mandatory) Mileage: (optional)

K Contact number of the new keeper: (optional)  
 Email address of the new keeper: (optional)  
 Driving licence number of the new keeper: (optional)

Official use only. Do not write in this space.

4008 675 3125 08 01 24  
 1569 / 1042293031 / 00211 41



ISC  
 [REDACTED]

Official use only

CV 2184095

8/23

Driver & Vehicle  
Licensing  
Agency

Registration number

UNITED KINGDOM  
UK REGISTRATION  
CERTIFICATE

## Registered keeper

You **must** make sure that the name and address printed here is correct. If it is not, see section 3.

Document reference number  
Don't share, keep it safe



1569\_1042293031\_00211\_1010\_404008



Acquired vehicle on 31 12 2023

Thinking of buying this vehicle?

## Buyer beware...

Do you know how to avoid being tricked into buying a stolen vehicle?

For tips and advice go to [gov.uk/checks-when-buying-a-used-car](https://gov.uk/checks-when-buying-a-used-car)



## THIS DOCUMENT IS NOT PROOF OF OWNERSHIP.

It shows who is responsible for registering and taxing the vehicle.

## Registration Certificate translations

свидетелство за регистрация  
Permiso de circulación  
Osvedčeni o registraci  
RegistreringsattestZulassungsbescheinigung  
Registreerimistunnistus  
Άδεια κυκλοφορίας/  
Πιστοποιητικό ΈγγραφήςCertificat d'immatriculation  
Teastas Cláraithe  
Carta di circolazione  
Registrācijas apliecībaRegistrācijas liudijimas  
Forgalmi engedély  
Čertifikat ta' Registrazzjoni  
KentekenbewijsDowód Rejestracyjny  
Certificado de matricula  
Certificat de immatriculare  
Osvedčenie o evidenciiPrometno dovoljenje  
Rekisteröintodistus  
Registreringsbeviset  
Prometna dozvola

## Data protection

DVLA handles your personal data in accordance with road vehicle law and data protection laws. The law allows us to release your data to the police and other enforcement bodies. We also provide data to other parties where the law allows it. For further information about how we process your data, your rights and who to contact, see our privacy notice at [gov.uk/dvla/privacy-policy](https://gov.uk/dvla/privacy-policy)

## Special notes (these notes cannot be removed)

NO. OF FORMER KEEPERS 1

1. DECLARED NEW AT FIRST REGISTRATION.

## How to fill in your V5C Registration Certificate (log book)

Tax or SORN (Statutory Off Road Notification) using the document reference number above.

## 1 Change my vehicle details

You **must** fill in section 1 over the page and return the whole V5C to DVLA, Swansea, SA99 1BA.  
For more information go to: [gov.uk/change-vehicle-details-registration-certificate](https://gov.uk/change-vehicle-details-registration-certificate)

## 2 Selling or transferring my vehicle to a new keeper (not a trader)

It's quick and simple to tell us online at: [gov.uk/sold-bought-vehicle](https://gov.uk/sold-bought-vehicle)  
Or fill in section 2 over the page and send to DVLA, Swansea, SA99 1BA.  
You must give section 6 to the new keeper.

## 3 Change my name or address or both

It's quick and simple to tell us your new address online at: [gov.uk/change-address-v5c](https://gov.uk/change-address-v5c)  
Or if your name and address has changed you **must** fill in section 3 over the page and return the whole V5C to DVLA, Swansea, SA99 1BA.

## 4 Selling, transferring or part exchanging this vehicle to a motor trader

It's quick and simple to tell us online at: [gov.uk/sold-bought-vehicle](https://gov.uk/sold-bought-vehicle)  
Or fill in section 4 over the page and return just that page to DVLA, Swansea, SA99 1BA.

## 5 Permanently exporting this vehicle for more than 12 months

If you or someone you're selling the vehicle to is taking it out of the country for 12 months or more, go to section 5 over the page.  
For more information go to: [gov.uk/taking-vehicles-out-of-uk](https://gov.uk/taking-vehicles-out-of-uk)

## 6 New keeper slip

Selling your vehicle: you **must** fill in the date of sale on section 6 over the page and give it to the new keeper.  
**Vehicle tax or SORN isn't passed on to someone else.**  
For more information go to: [gov.uk/vehicletaxrules](https://gov.uk/vehicletaxrules)

**Official use only**  
**Do not write in this space**

**Official use only**  
**Do not write in this space**



### 3 Change my name or address, or both – Enter full details for all changes

W

By submitting this form you are declaring that the information provided is correct.

If your personal details are wrong or have changed, you **must** tell us by filling in the boxes below giving us your full name or address, or both. Use **black ink and CAPITALS**. Send the **whole V5C** to DVLA, Swansea, SA99 1BA. For more information go to: [gov.uk/change-address-v5c](http://gov.uk/change-address-v5c)

Registration number  R

Document reference number

Title: Mr:  Mrs:  Miss:

Or other title, or business or company name:

First and middle names written in full:

Surname:

New UK address (house number, street name, town or city):

Contact number: (optional)

Email address: (optional)

Postcode:

4008 675 3125 08 01 24  
1569 / 1042293031 / 00211 41

### 4 Selling, transferring or part exchanging this vehicle to a motor trader

By submitting this form you are declaring that the information provided is correct.

A motor trader can be: motor dealer, motor auctioneer, vehicle dismantler, salvage dealer, finance and leasing company, insurance company, or car buying service.

If you want to keep the registration number you **must do this before** you sell or transfer it. To tell us go to: [gov.uk/keep-registration-number](http://gov.uk/keep-registration-number)

You **must** tell us **immediately** if you have sold or transferred your vehicle. It's quick and simple to tell us online. If you don't receive an acknowledgment or tax refund, if applicable, go to [gov.uk/contact-the-dvla](http://gov.uk/contact-the-dvla) as you may still be liable.

Or you can also use this form to tell us by filling in the boxes below. Use **black ink and CAPITALS**. Tear along the red perforated line and send the **whole section** to DVLA, Swansea, SA99 1BA.

Give the rest of the document to the motor trader.

Registration number  R

Document reference number

Name and address of motor trader:

VAT number:

Postcode:

01 Date of sale: (mandatory)

Mileage: (optional)

### 5 Permanently exporting this vehicle for more than 12 months

By submitting this form you are declaring that the information provided is correct.

If you are taking the vehicle out of the country for 12 months or more (a permanent export) you **must** fill in the boxes below. Use **black ink and CAPITALS**. Tear along the red perforated line and send the **whole section** to DVLA, Swansea, SA99 1BA.

You must keep the rest of your V5C – you will need this to register your vehicle abroad.

If you're selling the vehicle to a new keeper with a foreign address go to: [gov.uk/taking-vehicles-out-of-uk](http://gov.uk/taking-vehicles-out-of-uk)

Registration number  R

Document reference number

Date of export:

Which country are you exporting the vehicle to?

### 6 New keeper slip – must be given to the new keeper

Do not send this slip to DVLA on its own – you will not get a V5C.

You, the new keeper, must ensure the vehicle is taxed before you drive it.

You will be fined if our records show that the vehicle is not taxed, insured or no Statutory Off Road Notification (SORN) has been made.

It's quick and simple to tax online at: [gov.uk/vehicle-tax](http://gov.uk/vehicle-tax)

Declare the vehicle off road online at: [gov.uk/make-a-sorn](http://gov.uk/make-a-sorn)

You should receive your new V5C within 4 weeks of the registered keeper giving us your details.

If you do not receive your V5C, you'll need to fill in a V62 form to apply for a new one. Send it, with this slip, to DVLA, Swansea, SA99 1DD. Make sure the date of sale or transfer box is filled in.

For more details on this vehicle go to: [gov.uk/get-vehicle-information-from-dvla](http://gov.uk/get-vehicle-information-from-dvla)

For data protection information go to: [gov.uk/dvla/privacy-policy](http://gov.uk/dvla/privacy-policy)

Registration number  R

Document reference number (use this to tax online)

Date of sale or transfer:

24008 675 3125 08 01 24  
1569 / 1042293031 / 00211 41

Make SEAT  
Model ALHAMBRA SE LUX TDI S-A

Colour SILVER  
Engine size 1968 CC

Suspension type  
Tax class DIESEL CAR

No. of seats 7



This page is intentionally left blank

# APPENDIX E

## Essential Repairs

It is strongly advised that the essential defects are investigated and rectified prior to purchase.

**Comment**

**Additional Comments**

**NONE.**

*Report No: 10515*

7

## Advisable Repairs

Please note that the advisable items may prove costly to repair and must be considered.

Item	Comment
138	OSR WHEEL RIM DAMAGED "MOT ADVISORY"

Report No: 10515

### PLEASE READ CAREFULLY

- You are strongly advised to discuss the findings of this report with the vendor prior to making your decision to purchase the vehicle.
- Essential repairs should be investigated and rectified prior to purchase. These may be costly.
- Advisable repairs may prove costly to repair and must be considered prior to purchase.

Engineers Name  
Qualifications

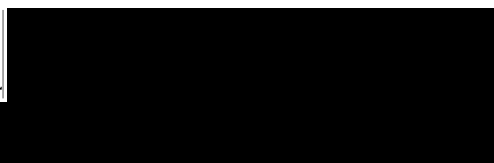

Date ..... 06/03/26 .....

## Engineers Comments

The vehicle is considered overall to be a fair and reasonable example of the type, being in a generally reasonable condition and generally considered to be consistent with the type for the age and indicated recorded mileage in most areas.

The items listed as "could not be checked" (---) normally indicate items were obscured by covers/shields or other equipment.

The Water pump – Engine drive belt/chain - these items could not be fully examined, as covers, trims and other equipment obscure them.

The cooling system was pressure tested to 0.7 bars, no pressure loss was noted on the system or pressure cap. The antifreeze concentration was acceptable, but has deteriorated from its original strength and at the next routine service may need to be refreshed/replaced. It is advised that the coolant strength be checked again at the next routine service. Antifreeze only has a 2/3-year life and requires its strength adjusting after this time or replacing as per manufacturer's specifications.

The vehicle is fitted with vented front brake disc and pads, supported at the rear by a single arrangement. Although the visible brakes only show some signs of general serviceable wear, some deterioration is noted, which will need attention in the near future. It is strongly advised to remove all road wheels and examine the inner brake components, which are obscured on this vehicle prior to purchase, replacing any worn or badly corroded parts. It is probable that the front brakes at least, will need to be replaced at the next routine service.

The steering & suspension has been assessed to MOT standard. This allows for a degree of wear and deterioration of components without rendering them unserviceable. The extent of wear is not considered excessive at this juncture and unlikely to attract MOT failure.

The road test distance and or top speed was limited due to the general area/inspection location, and/or traffic levels and/or adverse weather conditions and/or lack of fuel when the vehicle was tested and driven. Comment cannot be made in these instances in relation to possible "high speed" or "sustained speed," related driving defects, which may become apparent at a later stage after any purchase due to these limiting conditions.

## Vehicle documents and Inspection environment notes.

Engineer Indicate with "X" as applicable.

### Registration Document (V5):

- No registration document was seen with the vehicle and you are advised to satisfy yourself that the vehicle identification number and engine number (where quoted) correspond to those shown on this report. Warning: **DO NOT BUY ANY VEHICLE WITHOUT A V5.**
- The V5/Registration Document shows \_\_\_\_\_ previous keeper(s), the last change of Keeper on \_\_\_\_\_

### Security:

- The Master Key was not available. Please ensure this is supplied if the vehicle is purchased.
- The engineer recommends that relevant spare and service keys be obtained prior to purchase.
- Obtain hand books and radio codes for vehicle prior to purchase as these were not seen in the vehicle.

### M O T:

- As only a small amount of time is left on the MOT Certificate (less than 3 months) the engineer recommends a full year's MOT be obtained prior to purchase.
- A 12 Month MOT Certificate has been seen with the vehicle.

### Servicing:

- The service history seen, indicated that the last recorded service was carried out at \_\_\_\_\_ miles. No immediate servicing is necessary. Next service is due as per manufacturer's recommendations or as per the Vehicles Service indicator.
- The service history seen, indicated that the last recorded service was carried out on \_\_\_\_\_ miles. Therefore the engineer would suggest a full service and brake inspection to the manufacturer recommendations prior to purchase, which may reveal further defects not apparent at this examination.
- No service documentation seen with this vehicle and therefore the engineer would recommend a full service and brake inspection to the manufacturer's recommendations prior to purchase, which may reveal further defects not apparent at this examination.

### Inspection conditions notes:

- No vehicle hoist/ramp was available. A large trolley jack and stands were used in order to carry out underside checks. This limits the view of the underside. Some areas could not be fully seen. There *may* be further defects, which may be visible given clear access and view.
- The body/paintwork was wet/dirty/dusty this severely restricts inspection of the paintwork. Please note that there may be other defects present, which were not visible due to the obscured paintwork, but which may become visible once dry and clean.

Report No: 10515

**EXHAUST SYSTEM**

117. Manifold	S	120. Silencer(s)	S	123. System condition	S
118. Pipes	S	121. Heat shields / mountings	S		
119. Catalytic converter (s)	S	122. Joints / couplings	S		

**FUEL SYSTEM**

124. Tank	S	126. Fuel lines	S	128. Evidence of leaks	No
125. Tank fixings	S	127. Breather pipes	S		

**BRAKES**

129. Master cylinder security	S	132. Flexible hoses	S	135. Handbrake op / adjustment	S
130. Fluid leaks	No	133. Pipes / connections	S	136. Handbrake mechanism	S
131. Servo / power system	S	134. Discs / pads (if visible)	S	137. Pedal and pad / linkage	S

**Note** - If the vehicle is fitted with brake drums the internal parts including linings are not visible. Brake fluid should be replaced at the manufacturers specified intervals.

**WHEELS AND TYRES Type: Alloy**

It is recommended tyres be replaced when the tread depth reaches 2mm. If uneven tyre wear is noted, this may indicate incorrect geometry, which can result in excessive and rapid tyre wear. A full steering and geometry check is recommended.

138. Wheel Rims	A				
139. Wheel Trims	S				
	<b>Tyres</b>	<b>Make</b>	<b>Size</b>	<b>Type / Construction</b>	<b>Min tread depth</b>
140. Front RH	Nexen	225/50/17	Radial	5.0mm	S
141. Front LH	Nexen	225/50/17	Radial	5.0mm	S
142. Rear LH	Zeetex	225/50/17	Radial	5.0mm	S
143. Rear RH	Zeetex	225/50/17	Radial	5.0mm	S
144. Spare	Emergency inflation device				S

**145. ROAD TEST**

The road test has been undertaken within the speed limits and prevailing traffic conditions in the locality of the inspection. If a road test has not been carried out, please refer to the engineer's comments page.

\*If the vehicle is fitted with 4wd transmission then the systems have been checked for security, leakage and excessive noise. However, within the limitations of the road test the full functionality could not be checked.

<b>Test Distance</b>	<b>3 Miles</b>		<b>Speed achieved up to 40 MPH</b>		
146. Final drive operation / Noise level	S	153. Instrument /controls function	No	160. Road holding / stability	S
147. Gearbox operation / Noise level	S	154. Steering wheel alignment	S	161. General steering / handling	S
148. Engine performance	S	155. 4WD operation *	N/A	162. Footbrake operation	S
149. Engine noise	S	156. Clutch operation **	S	163. Hand/park brake operation	S
150. Excess smoke	No	157. Cooling fan operation	S	164. Suspension noise	No
151. Overheating evidence	No	158. Steering effort	S	165. Warning lights	S
152. Auto changes / kick-down	N/A	159. Hot restarting	S	166. Cruise control	S

\*\* It should be carefully noted that the life expectancy of clutches is uncertain and difficult to predict, being dependant on owners driving style, vehicle operation and terrain. The fact that the clutch has not been identified as faulty/slipping/juddering/noisy on the report does not and should not be taken to imply that the clutch assembly will have a continuing life expectancy from the time of our check. They can begin to slip at any time.

**FINAL CHECK**

167. Oil leaks	No	168. Coolant leaks	No	169. Uneven tyre wear	No
----------------	----	--------------------	----	-----------------------	----

Report No: 10515

<b>BODY EXTERIOR</b>			
1. Panel Condition / alignment	S	6. Door locks - operation	S
2. Paintwork	S	7. Fuel filler cover and cap	S
3. Exterior trim /grille	S	8. Soft top / Hard top (operation)	N/A
4. Glass	S	9. Body damage	S
5. Bumpers / No plates – Ft / Rr	S	10. Corrosion	No
		11. Mud flaps	S
		12. Body panels	S
		13. Bonnet catch	S
		14. Bonnet hinges	S

<b>ENGINE COMPARTMENT</b>	<input type="checkbox"/> PETROL	<input checked="" type="checkbox"/> DIESEL	<input type="checkbox"/> HYBRID	<b>No. of CYLINDERS: 4</b>	
15. Coolant Level / Condition	S	22. Power Steering – oil level	S	29. Turbo / supercharger	--
16. Coolant leaks	No	23. Clutch Fluid	S	30. Fuel pump / pipes	S
17. Antifreeze *	S	24. Brake Fluid	S	31. Accelerator linkage	S
18. Radiator / Cap	S	25. Engine Oil level	S	32. Cold starting	--
19. Hoses / Pipes	S	26. External leaks (upper engine)	S	33. Fast idle (cold)	--
20. Drive Belts	--	27. Engine mountings	S	34. Noise level (cold)	--
21. Water Pump (Not visible)	--	28. Fuel Injection	S	35. Excess fumes / smoke	No

**Note** - To ensure future serviceability, it is important that the engine camshaft belt is replaced at intervals specified by the manufacturer. It is in your best interests you ensure that this is carried out. \* Antifreeze only has a 2/3 year life span and requires its strength adjusting after this time or replacing as per manufacturers specifications.

<b>ELECTRICAL / CONTROLS</b>			
36. Starting system / Ignition lock	S	41. Rear lights & No. plate lights	S
37. Battery condition	S	42. Stop lights	S
38. Battery voltages:	S	43. Indicator/ Hazard lights	S
- Normal 12.15 volts	S	44. Reverse / Fog lights	S
- Starting 10.37 volts	S	45. Auxiliary lights	N/A
- Charging 14.75 volts	S	46. Interior / Panel lights	S
39. Headlights	S	47. Mirrors (electric)	S
40. Sidelights / running lights	S	48. Controls / Switches	S
		49. Instruments	S
		50. Horn	S
		51. Radio/Cass/CD/Aerial	S
		52. Heater / Fan controls	S
		53. Air Con operation	S
		54. Windows / Sun roof	S
		55. Wipers / Washers	S
		56. Headlamp wash / wipe	S

**Note** - We are unable to verify dash panel light and switch back lighting operation due to the daylight conditions. Please note that switching them "on or off" only assesses electrical components. Accuracy of instruments cannot be assessed.

<b>INTERIOR / LUGGAGE COMPARTMENT</b>		<b>NUMBER OF SEATS: 7</b>	
57. Steering Wheel / Adjustment	S	64. Door seals / hinges	S
58. Seat upholstery	S	65. Interior sills	S
59. Seat adjustment	S	66. Headlining / visors	S
60. Seatbelts	S	67. Sun roof	N/A
61. Carpets / Mats	S	68. Dash panel (condition)	S
62. Door trim panels	S	69. Cigarette lighter	N/A
63. Door fittings / operation	S	70. Mirrors (internal)	S
		71. Rear parcel shelf / load cover	--
		72. Boot / tailgate lock	S
		73. Luggage area trim con	S
		74. Illumination light	S
		75. Tool kit	S
		76. Hard / Soft top (condition)	N/A
		77. Tonneau cover	N/A

<b>FRONT SUSPENSION / STEERING / UNDER FRAME</b>			
78. Engine underside leakage	No	83. Wheel hubs / bearings	S
79. Steering joints/ ball joints	S	84. Springs/suspension units	S
80. Steering rack / box	S	85. Pipes / hoses	S
81. Chassis members	S	86. Dampers (condition / leaks)	S
82. Power steering (operation)	S	87. Gaiters	S
		88. Sub-frames mountings	S
		89. Suspension arms / mountings	S
		90. Tie bars / anti roll bars	S
		91. Corrosion protection	Yes
		92. Corrosion – floor/chassis	No

<b>REAR SUSPENSION / UNDER FRAME</b>			
93. Springs/suspension bars	S	97. Location rods/fixings	N/A
94. Anti roll bar	S	98. Bump stops/gaiters	S
95. Dampers/bushes	S	99. Wheel hubs/bearings	S
96. Suspension arms/fixings	S	100. Pipes/hoses	S
		101. Sub-frames/ mountings	S
		102. Chassis members	S
		103. Corrosion protection	Yes
		104. Corrosion -- floor/chassis	No

<b>CLUTCH / TRANSMISSION</b>		<input type="checkbox"/> MANUAL	<input checked="" type="checkbox"/> AUTOMATIC
105. Fluid / oil leaks	No	109. Casings	S
106. Cables / adjustments	N/A	110. Mountings	S
107. Hydraulic system	S	111. Drive shaft assembly	S
108. Linkage (wear)	S	112. Universal / sliding joints	S
		113. Backlash	S
		114. Gaiters	S
		115. Propshaft(s) / fittings	N/A
		116. Bearings / supports	N/A

**KEY:**

- S** satisfactory
- R** repainted
- =** scratch
- X** dent
- O** corrosion
- C** chip / rust
- P** previous repairs
- W** Wrap Missing

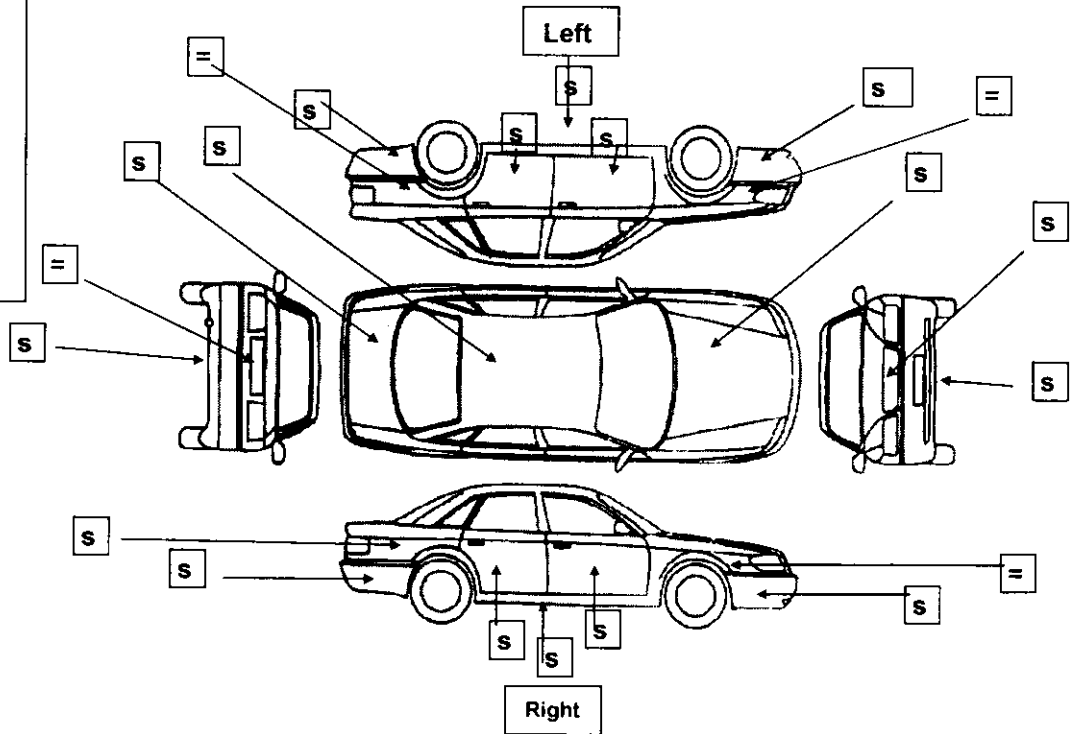

Minor blemishes, which are acceptable fair wear and tear for the vehicle's age, recorded mileage and type, are not recorded and you should satisfy yourself in this regard.

<b>EVIDENCE OF BODYWORK REPAIRS</b>	<b>Yes</b>	<b>X No</b>
<b>BODYWORK CLEAN</b>	<b>Yes X</b>	<b>No (See Notes)</b>

**KEY FOR POINTS ON FOLLOWING PAGES**

- S** Satisfactory for age and recorded mileage
- Could not be checked
- x** Essential repair requiring immediate attention
- A** Advisable repair should be considered prior to purchase
- N/A** Not applicable
- Y** Yes
- N** No

Please note: Right = Off side (O/S) and Left = Near side (N/S) as viewed from the driver's seat.

Report No: 10515

# EXETER CITY COUNCIL APPROVED VEHICLE INSPECTION REPORT.

## Customer Details

Report Date: 06/03/26

Report No: 10515



## Customer's contact details

Home:

Work:

Mobile:

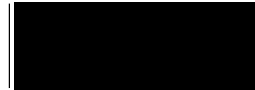

## VEHICLE DETAILS

Make Seat

Registration Number



Model Alhambra Tdi Se Lux

Colour

Silver

Vehicle Identity Number (VIN)



VIN Checked and confirmed  
on vehicle

Yes X No

V5/Registration document  
available and checked

MOT Certificate available and  
checked

Yes

Mileage reading In 136393  
(Not guaranteed) Out 136388

MOT Expiry Date

22/02/27

Vehicle Excise Licence Expiry

01/01/27

Date of inspection 06/03/26

Time of inspection

09:00

Location of vehicle



Lighting

Good

Weather.  
(See notes)

Good

Ramp available.  
(See notes)

Yes  No

## SECURITY CHECK

The vehicle identification number on this vehicle was checked and found to be **consistent** with the manufacturer's format.

## SUMMARY REPORT

**READY FOR USE** – No faults found, suitable for immediate use.

**ADVISABLE REPAIRS ONLY** – Suitable for immediate use but advisable repairs should be planned for.

**ESSENTIAL REPAIRS REQUIRED** – Not suitable unless all essential repairs are undertaken and advisable repairs, if any are planned for.

**UNSATISFACTORY** – Vehicle has significant deficiencies, which are judged to be impractical or uneconomical to repair to a satisfactory standard.

Please read all pages of this report

**VW - AUDI - SEAT - SKODA  
INDEPENDENT SPECIALIST**



**INVOICE TO:**

**DELIVERY ADDRESS IF DIFFERENT:**

**ORDER DATE:** 12-Mar-26

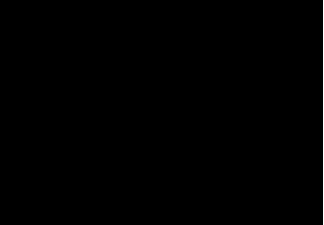

**DESPATCH DATE:** 13-Mar-26

**INVOICE NO:** M113750

DESCRIPTION	ADDITIONAL INFO	COST
SEAT ALHAMBRA FITS 2016 TO 2023 GENUINE 17 INCH DINAMICA ALLOY WHEEL	7N5601025G	£99.17
DELIVERY FEDEX NEXT-DAY TRACKING No: <b>889579942510</b>		£10.00
<b>SUBTOTAL</b>		<b>£109.17</b>
<b>VAT @ 20%</b>		<b>£21.83</b>
<b>TOTAL COST</b>		<b>£131.00</b>

**TERMS AND CONDITIONS**

1. All mechanical parts are guaranteed for 90 days from date of purchase.
2. All electrical parts are guaranteed for 30 days from date of purchase.
3. Unless explicitly stated all parts supplied are secondhand parts recovered from salvage vehicles. Distance Selling Regs are therefore not applicable.
4. Our guarantee is limited to replacement, repair, or contribution towards repair at our option
5. The guarantee will become void if parts are not fitted by an approved VW or Audi specialist.
6. The guarantee will become void if parts are dismantled or taken apart in any way.
7. We are not liable for any labour, inconvenience or any other costs which may arise from parts supplied by us.
8. The purchaser assumes all responsibility for any expenses incurred during installation and/or removal of any parts supplied by us.

**RETURNS**

9. All correctly supplied parts cannot be refunded or returned under any circumstances.
10. Any defects or discrepancies must be notified and the parts returned within 7 days from date of purchase.
11. The purchaser is responsible for the cost of return carriage and any damage caused to parts during return transit.
12. Refunds may only be issued after the goods have been returned. A handling charge to cover administration and restocking costs may be applied at our discretion.

**SERVICE ACCOUNT INVOICE No: 405727**

Invoice No	<b>405727</b>
Date	<b>17/03/26</b>
A/c No	<b>1459</b>
Job No.	<b>126094</b>
Order No	<b>NONE</b>
Page	<b>1</b>

Reg		Reg Date	<b>29/03/16</b>
Vehicle		Del Date	
Chassis N		Mileage	<b>136701</b>
Engine No		Next Service date	07/10/26
		Next MOT date	12/02/26

<b>REQUEST 1</b>			
<b>Replace o/s/r wheel with one in boot swapping tyre from o/s/r on to new wheel.</b>			
	Labour	VAT	Rate %
	17.52	3.50	20.0%
Replace o/s/r wheel with one in boot swapping tyre from o/s/r on to new wheel.	30.00	6.00	20.0%
<b>TOTAL CHARGE FOR REQUEST 1</b>		<b>57.02</b>	

Service Advisor  
Technician

SERVICE Total	<b>47.52</b>
VAT Total	<b>9.50</b>
Invoice Total	<b>57.02</b>

Ask us about our Service Plans starting from £19.00 per month!

VAT Registration No 737 188 406

This page is intentionally left blank

# APPENDIX G



Small dent in rear to be fixed



Key scratch being fixed



This page is intentionally left blank

## REPORT TO LICENSING SUB COMMITTEE

<b>Date of Hearing:</b>	<b>15.04.2026</b>
<b>Report of:</b>	<b>Jasmine Williams Licensing Officer</b>
<b>Decision Required:</b>	<b>RENEWAL of a licence relating to a Private Hire vehicle over 10 years old.</b>
<b>Legislation:</b>	<b>Local Government (Miscellaneous Provisions) Act 1976</b>
<b>Applicant:</b>	██████████

### 1. What is the report about?

- 1.1 An application is attached at Appendix A that has been received from the Applicant, a licensed private hire operator and driver seeking permission for the renewal of a private hire vehicle licence for a vehicle which is over 10 years old. The vehicle was 10 years old on the 28<sup>th</sup> March 2026. This is a matter that cannot be dealt with under the delegated powers.

### 2. Background:

- 2.1 The vehicle that is being presented for licensing as a private hire vehicle is a 4 passenger Seat Tesla, registration number ██████████, with a date of first registration of 28<sup>th</sup> March 2016. A copy of the vehicle registration document is attached within Appendix D.

### 3. Report Details:

- 3.1 The vehicle has a current MOT certificate dated 3rd March 2026 and expires 20<sup>th</sup> March 2027. The mileage recorded at the MOT inspection was 141,160 miles. The MOT certificate and MOT history are included within Appendix C and vehicle insurance is included within Appendix B. In addition to the MOT certificate there is an independent mechanical inspection report, which has been submitted, this is dated ██████████ and is attached as Appendix E. Photos for the vehicle are attached at Appendix F. Upon inspection by a Council Officer the vehicle was found to be in excellent condition for the age. The vehicle was first plated by Exeter City Council on 30<sup>th</sup> March 2016 and has been continuously licensed since that date.
- 3.2 The Licensing Sub-Committee must have regard to the Council's Practices and Procedures for the control of Hackney Carriage and Private Hire Vehicles, Drivers and Operators and the Code of Conduct for Licensed Drivers ('Taxi Policy').
- 3.3 Vehicles presented for renewal that are more 10 years old, shall not be granted. However, the Applicant will be given the right to apply for the application to be considered by a licensing sub-committee if they feel that their particular circumstances justify a deviation from the existing Policies.

#### **4. What are the legal aspects?**

4.1 Section 48(1) of the Local Government (Miscellaneous Provisions) Act 1976 ('the Act') states that a district council may on receipt of an application from the proprietor of any vehicle for the grant in respect of such vehicle of a licence to use the vehicle as a private hire vehicle, grant in respect thereof a vehicle licence:

Provided that a district council shall not grant such a licence unless they are satisfied-

a) that the vehicle is-

- i) suitable in type, size and design for use as a private hire vehicle;
- ii) not of such design and appearance as to lead any person to believe that the vehicle is a hackney carriage;
- iii) in a suitable mechanical condition;
- iv) safe; and
- v) comfortable;

b) that there is in force in relation to the use of the vehicle a policy of insurance or such security as complies with the requirements of Part VI of the Road Traffic Act 1988, and shall not refuse such a licence for the purpose of limiting the number of vehicles in respect of which such licence are granted by the council.

4.2 Under Section 48(4)(c) of the Act the Licensing Sub-Committee may grant a licence for a maximum period of 12 months.

4.3 Any person aggrieved by a refusal of the Licensing Sub-Committee to grant a vehicle licence under Section 48 of the Act may appeal to the Magistrates Court within 21 days of receiving written notice of the refusal.

#### **5. Recommendations:**

5.1 The Licensing Sub-Committee are asked to determine the application having regard to current policy.

#### **Service Lead – Environmental Health & Community Safety**

Author: Jasmine Williams

#### **Local Government (Access to Information) Act 1972 (as amended)**

Background papers used in compiling this report:-  
None

Contact for enquires:  
Democratic Services (Committees)  
Room 4.36  
01392 265275

**A**

**APPLICATION FOR THE RENEWAL OF A  
A HACKNEY CARRIAGE OR PRIVATE HIRE VEHICLE LICENCE**

*(Some details on this form are pre-filled from our records – if any of these details are incorrect, please use the blank space provided to give the correct details)*

<b>Name:</b>	
<b>Address:</b>	

<b>Telephone</b>		<b>Email:</b>	
<b>Mobile</b>		<b>Vehicle registration number</b>	

<b>Type of licence held:</b>	Private Hire Vehicle	<b>Vehicle Plate Number:</b>	
<b>Licence expiry date:</b>	29.03.2026	<b>Driver License No.</b>	

Any other person who is a proprietor of the vehicle or who is concerned either solely or in partnership with any other person in the keeping, employing or letting of hire of the vehicle.

Name	Address

I hereby apply for a licence for the motor vehicle identified in this application to be used as a \*Private Hire Vehicle\* within the City of Exeter and I hereby declare that all particulars entered on the form are true and correct to the best of my knowledge and belief. *(\*Delete which does not apply)*

VEHICLE DETAILS		
Make of vehicle:	Model of vehicle:	Number of passengers:
Tesla	Model S	4
<b>Vehicle Registration Document number:</b>		<b>Date of first registration:</b>
		28.03.2016

<b>Details of current vehicle insurance:</b>	<b>Date insurance expires:</b>
Axa	15.12.2026

<b>Where will the vehicle be kept when not in use? (address):</b>	[REDACTED]

<b>In respect of Private Hire Vehicles, by which Operator, and from what address will the Private Hire Vehicle be operated?</b>	
<b>Name of Operator:</b>	[REDACTED]
<b>Address of Operator:</b>	[REDACTED]

**When an application involves the substitution or exchange of an existing vehicle by a new one, please answer the following questions:**

Will the replaced vehicle continue to be used as a Licensed Private Hire/Hackney Carriage vehicle?	<b>YES</b>	<b>NO</b>
	N/A	N/A
If NO, please specify reason: (i.e. private use, taken off road, etc.)		
If continuing to be used as a Licenced vehicle, please give name and address of new owner:		
Make of existing licenced vehicle:	Tesla Model S	
Registration number of existing licenced vehicle:	[REDACTED]	

I understand that omissions or incorrect statements will render the Licence if granted, liable to suspension or revocation and render me liable to prosecution.

I have been given a copy of the conditions relating to this Licence.

SIGNED [REDACTED] DATED [REDACTED]

See over for notes.

Any changes in the circumstances which might render any of the above information incorrect must be immediately reported to the Office of the Assistant Director Environment, Exeter City Council, Paris Street, Exeter, EX1 1RQ

**NB: INFORMATION DISCLOSED ON THIS FORM MAY BE REVEALED TO OTHER AGENCIES AND BODIES FOR THE SOLE PURPOSE OF PREVENTING OR DETECTING CRIMES.**

**Private Hire Vehicle Renewal Procedure:**

Licenses for Private Hire vehicles are issued for a maximum of 12 months at any one time. Vehicles presented for renewal that are less than 8 years old can be renewed by Licensing Officers under delegated powers.

Vehicles presented for renewal that are between 8 and 9 years old can be renewed by Licensing Officers under delegated powers provided that the vehicle is presented for inspection in a satisfactory condition, and a comprehensive report provided into the mechanical fitness of the vehicle has been undertaken by the AA, RAC, or DEKRA, or any other approved engineer, and any essential works identified have been carried out and evidence provided to establish this. If Officers are in doubt as to the fitness or suitability of a vehicle to carry on as a licenced vehicle then they shall refer the application to the Sub-committee for determination.

Vehicles presented for renewal that are between 9 and 10 years old will be referred to the licensing sub-committee for determination. Applicants will be advised to provide a comprehensive report into the mechanical fitness of the vehicle as outlined above.

*Vehicles presented for renewal that are more 10 years old, shall not be granted. However the applicant will be given the right to apply for the application to be considered by a licensing sub-committee if they feel that their particular circumstances justify a deviation from the existing Policies.*

<b>Office use only</b>			Plate Number:	P419
Fee paid:		Date:		Receipt No.:
<b><u>INSPECTION OF:</u></b>			<b><u>SATISFACTORY:</u></b>	
1. Insurance	YES		NO	
2. Fire Extinguisher/First Aid Kit	YES		NO	
3. Cleanliness	YES		NO	
4. Advertising Signs	YES		NO	
5. Meter	YES		NO	
6. Plate fixing	YES		NO	
7. Tariff	YES		NO	
8. Bus Lane stickers	YES		NO	

Licence to be issued:	YES		NO	
-----------------------	-----	--	----	--

NOTES:				
--------	--	--	--	--

Date checked by officer:		SIGNED (officer)		
--------------------------	--	------------------	--	--

**B**

## IMPORTANT

THESE NOTES ARE FOR  
YOUR GUIDANCE

To ensure full protection under your policy it is essential to notify your broker of any change to the details previously supplied such as:

aaaa) Change of address, occupation, vehicle(s) declared or use of your car/vehicle.

bbbb) Motoring convictions and/or summons pending/accidents.

\*\*\*\*\*

### WARNING

It is an offence if any person for the purpose of obtaining the grant of any license to himself/herself or any other person knowingly makes any false statement, or for the purpose of obtaining the issue of a certificate of insurance or of a certificate of security under the relevant law applicable in Great Britain, Northern Ireland, the Isle of Man, the Island of Guernsey, the Island of Jersey and the Island of Alderney, makes any false statement or withholds any material information.

## CERTIFICATE OF MOTOR INSURANCE



Certificate no. [REDACTED]

235. Description of vehicles  
[REDACTED]

236. Name of Policyholder  
[REDACTED]

237. Effective date of the commencement of insurance for the purposes of the relevant law  
16/12/2025

238. Date of expiry of insurance  
15/12/2026

239. Persons or classes of persons entitled to drive The Policyholder and any person  
[REDACTED]

Provided that the person driving holds a licence to drive the vehicle, or has held and is not disqualified from holding or obtaining such a licence, and is driving on the Policyholder's order or with his permission.

240. Limitations as to use

For social, domestic and pleasure purposes and in connection with the Policyholder's business including carriage of passengers for private hire.

### The policy does not cover –

Use for racing, pace-making, speed test, rallies, trials or competition, or use for hire or reward other than private hire

I hereby certify that the policy to which this certificate relates satisfies the requirements of the relevant law applicable in Great Britain, Northern Ireland, the Isle of Man, the Island of Guernsey, the Island of Jersey and the Island of Alderney.

**Tara Foley**

CEO AXA UK & Ireland

Note: For full details of the insurance cover reference should be made to the policy.

Cancellation - if this policy is cancelled this Certificate will no longer be valid and the vehicle will be removed from the Motor Insurance Database from the cancellation date.

ADVICE TO THIRD PARTIES – NOTHING CONTAINED IN THIS CERTIFICATE AFFECTS YOUR RIGHTS AS A THIRD PARTY TO MAKE A CLAIM.

“THIS CERTIFICATE OF MOTOR INSURANCE HAS BEEN PREPARED ON A LASER PRINTER AND IS NOT VALID IF IT HAS BEEN ALTERED IN ANYWAY”

### Windscreen Repair or Replacement Service:

You will need to show your Certificate of Motor Insurance to the supplier. Windscreen excess £60

This insurance also applies throughout the European Union and in Liechtenstein, Norway, Iceland, Switzerland and Andorra. This gives the minimum cover required by the law in each of the above countries.

Cette assurance est également valable dans tous les pays de L'Union Europeene au Lichtenstein, en Norvege, en Islande, en Suisse et en Andorre. Elle offre au moins la couverture minimum exigee par la loi de chacun de ces pays.

Die vorliegende Versicherung gilt auch uberall in den Landern der Europaischen Union, Liechtenstein, Norwegen, Island, Schweiz und in der Andorra. Die Versicherung auf jeden Fall die fur die jeweiligen Lander gesetzlich geforderte Mindestdeckung.

La presente Assicurazione e valida per tutti paesi della Comunita Europea e nei paesi di sequito elencati, Liechtenstein, Norvegia, Islanda, Svizzera e Andorra, fornendo la copertura minima richiesta dalle leggi previste in materia in ognuno di questi paesi.

Este seguro tambien tiene validez en todos los paises de la Union Europea y en Liechtenstein, Noruega, Islandia, Suiza y Andorra. Ofrece al menos la cobertura minima especificada por la ley an cada uno de estos paises.



C

# MOT test certificate



Driver & Vehicle  
Standards  
Agency

① Vehicle identification number

[REDACTED]

②a Registration number      ②b Country of registration

[REDACTED]

**GB**

Make and model

**TESLA MODEL S**

⑤ Vehicle category

**M1**

④ Mileage

**141,160 miles**

Mileage history

**137,699 miles**    26.02.2025

**136,159 miles**    26.02.2024

**124,870 miles**    23.02.2023

⑦ **Pass**

③e Date of the test

**03.03.2026**

③ Expiry date

**20.03.2027**

To preserve the anniversary of the expiry date, the earliest you can present your vehicle for test is 21.02.2027.

③ Location of the test

[REDACTED]

⑨ Testing organisation and inspector name

[REDACTED]

MOT test number

[REDACTED]

Duplicate certificate issued by DVSA on 03 March 2026

Check that this document is genuine by visiting [www.gov.uk/check-mot-history](http://www.gov.uk/check-mot-history)

If any of the details are not correct, please contact DVSA by email at [enquiries@dvs.gov.uk](mailto:enquiries@dvs.gov.uk) or by telephone on 0300 1239000.

Receive a free annual MOT reminder by subscribing at [www.gov.uk/mot-reminder](http://www.gov.uk/mot-reminder) or by telephone on 0300 1239000.

Date tested  
**3 March 2026**

**PASS**

Mileage  
**141,160 miles**

Test location

▶ [View test location](#)

MOT test number

Expiry date  
**20 March 2027**

Date tested  
**26 February 2025**

**PASS**

Mileage  
**137,699 miles**

Test location

▶ [View test location](#)

MOT test number

Expiry date  
**20 March 2026**

Date tested  
**26 February 2024**

**PASS**

Mileage  
**136,159 miles**

Test location

▶ [View test location](#)

MOT test number

Expiry date  
**20 March 2025**

Date tested  
**23 February 2023**

**PASS**

Mileage  
**124,870 miles**

Test location

▶ [View test location](#)

MOT test number

Expiry date  
**20 March 2024**

Date tested  
**24 February 2022**

**PASS**

Mileage  
**107,210 miles**

Test location

▶ [View test location](#)

MOT test number

Expiry date  
**20 March 2023**

Date tested  
**17 March 2021**

**PASS**

Mileage  
**96,999 miles**

Test location

▶ [View test location](#)

MOT test number

Expiry date  
**20 March 2022**

Date tested  
**17 March 2020**

**PASS**

Mileage  
**92,779 miles**

Test location

▶ [View test location](#)

MOT test number

Expiry date  
**20 March 2021**

Monitor and repair if necessary (advisories):

- **Nearside Rear Tyre worn close to legal limit/worn on edge (5.2.3 (e))**
- **Offside Rear Tyre worn close to legal limit/worn on edge (5.2.3 (e))**
- **Nearside Front Tyre worn close to legal limit/worn on edge (5.2.3 (e))**

▶ [What are advisories?](#)



Date tested  
**1 March 2019**

**PASS**

Mileage  
**76,427 miles**

Test location

▶ [View test location](#)

MOT test number  
[REDACTED]

Expiry date  
**20 March 2020**

### The MOT test changed on 20 May 2018

Defects are now categorised according to their severity - dangerous, major, and minor. [Find out more.](#)

Date tested  
**1 March 2018**  
**PASS**

Mileage  
**56,100 miles**

Test location

▶ [View test location](#)

MOT test number  
[REDACTED]

Expiry date  
**20 March 2019**

### Safety recalls

No recalls found.

This information is provided by the manufacturer. Contact your local TESLA dealership if you think this information is wrong.

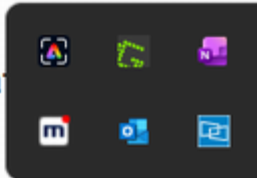

D



Registration number



# THIS DOCUMENT IS NOT PROOF OF OWNERSHIP.

It shows who is responsible for registering and taxing the vehicle.



Driver & Vehicle  
Licensing  
Agency

# UNITED KINGDOM UK REGISTRATION CERTIFICATE

## European Community

свидетелство за регистрация  
Permiso de circulación  
Osvědčení o registraci  
Registreringsattest  
Zulassungsbescheinigung  
Registreerimistunnistus

Άδεια κυκλοφορίας /  
Πιστοποιητικό Εγγραφής  
Certificat d'immatriculation  
Teastas Cláraithe  
Carta di circolazione  
Reģistrācijas apliecība

Registracijos liudijimas  
Forgalmi engedély  
Čertifikat ta' Reġistrazzjoni  
Kentekenbewijs  
Dowód Rejestracyjny  
Certificado de matrícula

Certificat de înmatriculare  
Osvedčenie o evidencii  
Prometno dovoljenje  
Rekisteröintodistus  
Registreringsbeviset  
Prometna dozvola

### 1. Registered keeper



You must make sure that the name and address printed here is correct. If it is not, see section 12.

Document reference number

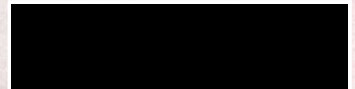

Thinking of buying this vehicle?

### Buyer beware...

Do you know how to avoid being tricked into buying a stolen vehicle?

For tips and advice go to [www.gov.uk/checks-when-buying-a-used-car](http://www.gov.uk/checks-when-buying-a-used-car)



### 2. The previous registered keeper

[Z.1] NONE

[Z.2]

[Z]

### 3. Special notes (these notes cannot be removed)

1. DECLARED NEW AT FIRST REGISTRATION.

4. Vehicle details

A Registration number [REDACTED] 2 [A.1] Validation character **V** 3

B Date of first registration 28 03 2016

[B.1] Date of first registration in the UK 28 03 2016

D.1 Make TESLA

D.2 Type 002

Variant 90D

Version B19B5

D.3 Model MODEL S 90D

D.5 Body type LIMOUSINE

[X] Taxation class ELECTRIC

[D.6] Suspension Type

[Y] Revenue weight

P.1 Cylinder capacity (cc)

V.7 CO<sub>2</sub> (g/km)

P.3 Type of fuel ELECTRICITY

S.1 Number of seats, including driver 5

S.2 Number of standing places (where appropriate)

[D.4] Wheelplan 2-AXLE-RIGID BODY

J Vehicle category M1

K Type approval number [REDACTED]

P.2 Max. net power (kW) 67

E VIN/Chassis/Frame No. [REDACTED]

P.5 Engine number L2S

F.1 Max. permissible mass (exc. m/c) 2640

G Mass in service 2184

Q Power/Weight ratio (kW/kg) (only for motorcycles)

R Colour BLACK

O Technical permissible maximum towable mass of the trailer:

O.1 braked (kg)

O.2 unbraked (kg)

U Sound level:

U.1 stationary (dB(A))

U.2 engine speed (min-1)

U.3 drive-by (dB(A))

V Exhaust Emissions:

V.1 CO (g/km or g/kWh)

V.2 HC (g/km or g/kWh)

V.3 NOx (g/km or g/kWh)

V.4 HC+NOx (g/km)

V.5 particulates (g/km or g/kWh)

5. Registered keeper

If any details are wrong enter the correct details in section 6, sign section 8, and return to DVLA

C.4.c - This document is not proof of ownership.

C.1.2  
C.1.1  
C.1.3

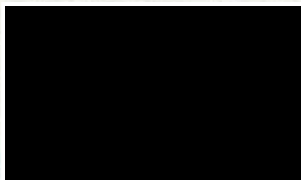

I

Please write in black ink and CAPITAL LETTERS.

6. New keeper or new name/new address details  
Please see section 12

Mr 1 Mrs 2 Miss 3 Please tick  the appropriate box **W** 4

Title (for example, Ms, Rev and so on) or business name:

First names: 5

Surname: 6

For company use only DVLA/DVA Fleet number 7

Date of birth (not required by law) Postcode: Please help us to help you by giving your postcode.

**DIDMMYYYY** 8 9

House No: 10

Address: 11

Post town:

New keeper? If so tick this box: **K** 12 Date of sale or transfer: **DIDMMYY** 13

Driving licence number of the new keeper (not required by law)

Present mileage (not required by law) 15

**R** 16 **S** 17

7. Changes to current vehicle

Only enter corrected or altered details

H 19

Wheelplan / Body type 20

VIN / Chassis / Frame Number 21

New revenue weight 22 Date of change 23 Cylinder capacity (cc) 24

No. of seats inc. driver 25 No. of standing places 26 Type of fuel 27

Engine number 28

New colour 29 Date of change 30 CLR

Tax class\* **Y** 31 32

\*The tax class shown in section 4 can only be changed when taxing. Please apply at your nearest Post Office\*.

8

**Declaration - You MUST sign, date and return this page to DVLA, Swansea, SA99 1BA when you notify any changes.**

**Registered keeper:** I declare that the new details I have given are correct to the best of my knowledge.

**New keeper:** I declare that this vehicle was sold or transferred to me on the date shown in section 6 and my name and address are correctly shown.

Signature: Date:

Signature: Date:

**Law:** If the vehicle is sold or transferred, both the registered keeper and the new keeper must sign this Certificate.

Official use only - Please do not write below this line.

981

Date of sale or transfer

Present mileage

00

D M Y Y Y

\* You are not required by law to provide mileage information

## Name and address of motor trader

Business name:
Address:
Post town:
Postcode:
VAT number:

## Declaration Please read the notes over the page before signing.

## Registered keeper:

I declare that I sold or transferred this vehicle to the motor trader, insurer or dismantler named in this section on the date shown.

Signature: \_\_\_\_\_ Date: \_\_\_\_\_

## Motor trader, insurer or dismantler:

I declare that this vehicle was sold or transferred to me on the date shown in this section.

Signature: \_\_\_\_\_ Date: \_\_\_\_\_

**The Law:** If the vehicle is sold or transferred both the registered keeper and the motor trader, insurer or dismantler must sign this section. The registered keeper must then return it to DVLA.

Document Ref. No.  
Despatch Codes

## 10. New keeper's details – To be kept by the new keeper. Do not return to DVLA (see notes over the page)

Please tear along dotted line

V5C/2

Registration number		Validation character	V	Make	TESLA
Please write new keeper's name and address in black ink				Model	MODEL S 90D
Write date of sale/transfer here				Suspension Type	
Doc. Ref. No.				Date of first registration	28 03 2016
Despatch Codes				Wheelplan	2-AXLE-RIGID BODY
				Revenue weight	
				*Taxation class	ELECTRIC
				Type of fuel	ELECTRICITY
				Cylinder capacity	
				CO2	
				No. of seats inc. driver	5

This will not produce a Registration Certificate.

\*The tax class shown can only be changed when taxing. Please apply at your nearest Post Office®.

## 11. Notification of permanent export – Please fill in and return to DVLA (see notes over the page)

Please tear along dotted line

V5C/4

Registration number		Validation character	V
Date of export			
Document Ref. No.			
Despatch Codes			

This section will not produce an export certificate. The V5C replaces the need for a separate export certificate.

## Declaration Please read the notes over the page before signing.

I declare that the vehicle will be exported on the date shown.

Signature: \_\_\_\_\_

Date: \_\_\_\_\_

## 12. What you need to know about the V5C

## Selling or transferring your vehicle privately

What you, the person selling the vehicle as current registered keeper, must do. Failure to tell DVLA may result in a fine or prosecution.

- Fill in section 6. (Give the name and UK address of the new keeper (buyer).
- Fill in section 10 (V5C/2) and give it to the new keeper.
- Sign and date the declaration in section 8 along with the new keeper.
- Keep a record of the new keeper's name and address.
- Tear off and return section 1 – 8 to DVLA, Swansea SA99 1BA.

## What the person buying the vehicle must do

- Sign and date the declaration in section 8 along with the seller.
- Keep section 10 (V5C/2) until you get your Registration Certificate
- Tax your vehicle immediately using section 10 (V5C/2).

## What we will do

- Update our vehicle record with the new registered keeper details.
- Send you, the current registered keeper (the seller), an acknowledgement within 4 weeks to confirm you are no longer liable for the vehicle, and issue an automatic refund of vehicle tax (if applicable). If you paid the vehicle tax by Direct Debit, the Direct Debit will be cancelled.

If you do not get an acknowledgement letter from us phone DVLA Customer Enquiries on 0300 790 6802, as you could be liable for the vehicle and may get a penalty and/or be prosecuted. If you are deaf or hard of hearing and have a textphone, phone 0300 123 1279.

## Your name and/or address details

- If the registered keeper details in section 1 are wrong or you want to change your name or address fill in section 6, sign the declaration and return the whole certificate to DVLA, Swansea, SA99 1BA. (You should also make sure you tell us about these changes on your driving licence by sending it to DVLA, Swansea, SA99 1BN).

There is more information on the website at

[www.gov.uk/vehicle-registration](http://www.gov.uk/vehicle-registration)

## Data Protection Act – Release of information

Your information may be disclosed in a number of lawful circumstances. Please go to [www.gov.uk/data-protection](http://www.gov.uk/data-protection) for more information.

E

# VEHICLE EXAMINATION REPORT

## **YOUR ATTENTION IS DRAWN TO THE TERMS AND CONDITIONS BELOW**

The examination of the vehicle described in this report was of a purely external, visual nature and excludes any dismantling. No responsibility can be accepted for defects not visibly present at the time, or those not detected which fall outside the scope of the examination and (where possible) its limited road test. Road tests, when possible, are conducted for a limited duration and exclude high speed testing. The accuracy of the instrumentation within the vehicle (speedometer, odometer, fuel and temperature gauges etc.), cannot be verified, neither can the future life expectancy of the clutch and brake linings, or the failure of mechanical components in the future. Statements on fuel and oil consumption levels will also be excluded.

Inspection Date: 03/03/2026

### **VEHICLE DETAILS**

Make & Model	<b>Tesla Model S</b>	Registration No.	
Colour	<b>Black</b>	Engine CC	<b>Electric</b>
Vehicle Identity Number. (VIN No.)		Confirmed	<b>Yes</b>
Engine No: L2S			
V5 Registration doc checked	<b>NO</b>	MOT Certificate Expires	<b>20.03.2027</b>
Odometer Reading	<b>141168 MILES</b>	Service Records Seen	<b>NO</b>

### **MECHANIC SUMMARY**

**PLEASE READ ALL THE PAGES OF THE REPORT**

**Vehicle in good condition**

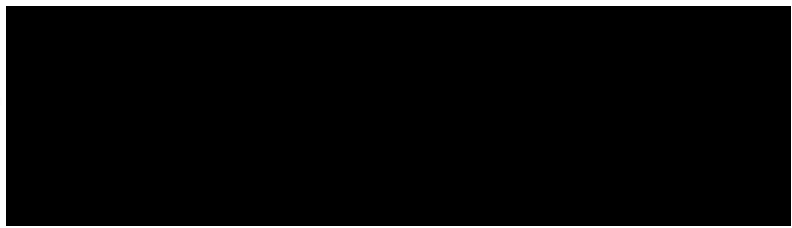

**EXTERIOR PANELS**

**KEY:**

- A acceptable
- G good
- R repaired
- = scratch
- X dent
- C corrosion
- O chip / rust
- D decals
- P poor condition
- not checked

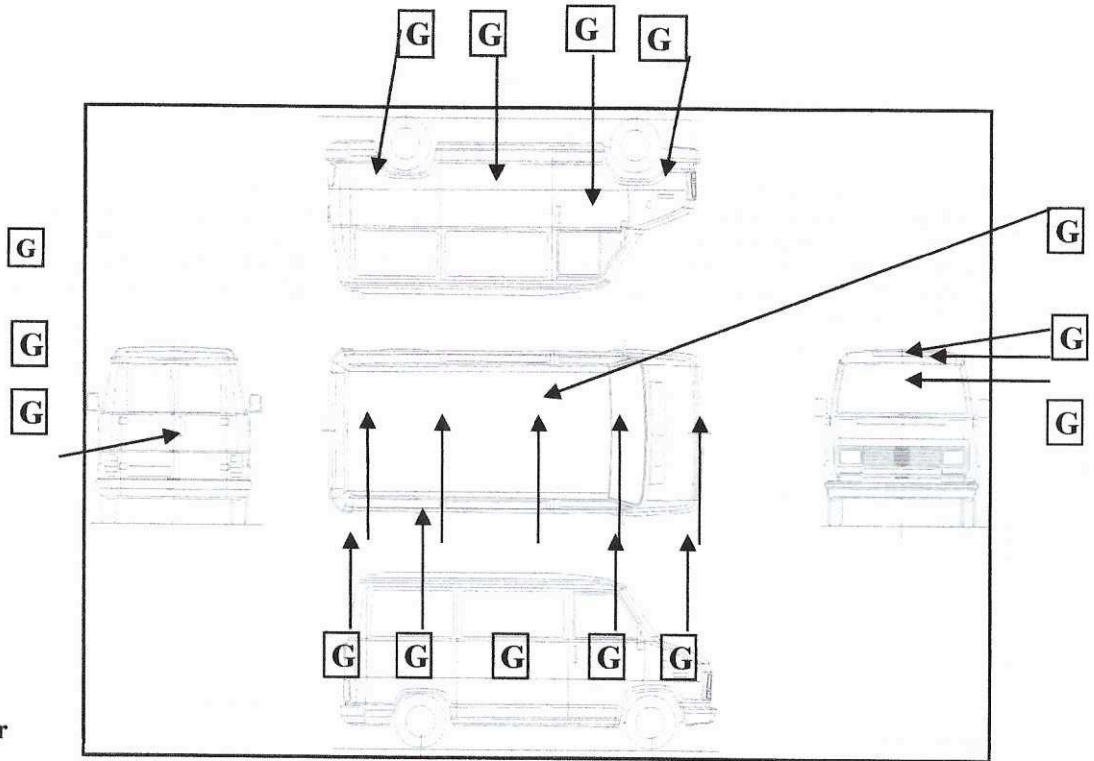

Paint Colour: Silver

Minor blemishes, which are acceptable for the vehicle's age and type, are not recorded and you should satisfy yourself in this regard.

**EVIDENCE OF BODYWORK REPAIRS**      **NO** No Major Repairs seen

Comments

**KEY FOR POINTS ON FOLLOWING PAGES**

- S Satisfactory for age and recorded mileage
- Could not be checked
- x Needs immediate attention
- A Advisable repair
- N/A Not applicable
- Y Yes
- N No
- C See Engineer's comments

**BODY EXTERIOR**

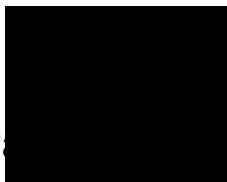

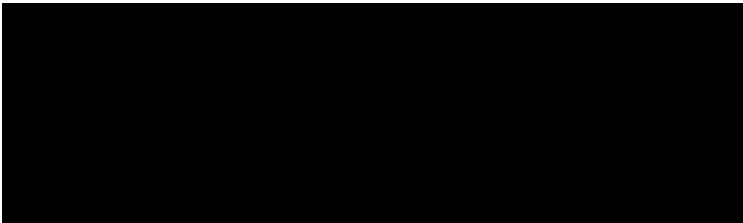

<b>ELECTRICAL / CONTROLS</b>					
37. Starting system/Ignition lock	S	43. Stop lights	S	51. Horn	S
38. Battery charging system	S	44. Indicator/Hazard lights	S	52. Radio/Cass./CD/Aerial	S
39. Voltages at battery:	S	45. Reverse / Fog lights	S	53. Heater(s) / Fan controls	S
normal	S	46. Auxiliary lights	S	54. Air Con operation	S
charging	S	47. Interior / Panel lights	S	55. Door locking	S
40. Headlights	S	48. Screen dimisters SELECT	S	56. Windows	S
41. Sidelights /Running lights	S	49. Mirrors (electric)	S	57. Wipers/Washers	S
42. Rear and No. plate lights	S	50. Controls/Instruments	S	58. Headlamp washers	S
1. Panel Condition/Alignment	S	5. Bumpers No plates – F/R	S	9. Body damage	N/A
2. Paintwork	S	6. Door locks – operation	S	10. Corrosion	S
3. Exterior trim	S	7. Fuel filler cover and cap	S	11. Mud flaps	N/A
4. Glass	S	8. Elevating Roof (operation/cond..)	S	12.	

<b>ENGINE COMPARTMENT</b>		<b>Electricity</b>			
13. Coolant Level/Condition	N/A	21. Clutch Fluid	N/A	29. Accelerator linkage	S
14. Coolant leaks	NO	22. Brake Fluid	S	30. Body panels	S
15. Antifreeze	N/A	23. Engine Oil level	N/A	31. Bonnet catch	S
16. Radiator/Cap	N/A	24. External leaks (engine)	NO	32. Bonnet hinges	S
17. Hoses/Pipes	N/A	25. Engine mountings	N/A	33. Cold starting	N/A
18. Drive Belts	N/A	26. Fuel Injection	N/A	34. Fast idle (cold)	N/A
19. Water Pump	N/A	27. Turbocharger	N/A	35. Noise level (cold)	N/A
20. Power Steering	S	28. Fuel pump/Pipes	N/A	36. Excess fumes/smoke	N/A

Spark plugs, Injectors or Glow Plugs are not removed.  
 It should be noted that a gas analyser has not been used to check exhaust emissions.  
 If no documentation is seen indicating camshaft drive belt replacement, to ensure future serviceability, it is important that the belt is replaced immediately and then at intervals specified by the manufacturer. It is in your best interests that you ensure that this is carried out.

<b>INTERIOR / LUGGAGE COMPARTMENT</b>					
59. Steering Wheel/Adjustment	S	66. Door seals /hinges	S	73. Rear parcel shelf/blind	S
60. Seat upholstery – F/R	S	67. Interior sills	S	74. Boot/tailgate lock	S
61. Seat adjustment	S	68. Headlining/visors	S	75. Luggage/Load area trim con	S
62. Seatbelts – F/R	S	69. Sun roof(s)	S	76. Illumination light	S
63. Carpets – F/R	S	70. Dash panel (condition)	S	77. Tool kit etc	S
64. Door trim panels	S	71. Cigarette lighter(s)	S	78. Living Area (Visual Only)	N/A
65. Door fitting /operation	S	72. Mirrors (internal)	S	79.	

<b>FRONT SUSPENSION / STEERING / UNDERFRAME</b>					
80. Engine underside leakage	NO	85. Wheel hubs/bearings	S	90. Sub-frames/mountings	S
81. Steering joints/ball joints	S	86. Springs/suspension units	S	91. Suspension arms/mountings/joint	S
82. Steering Rack and Pinion	S	87. Sphrers/Pipes/Hoses	N/A	92. Tie bars/anti roll bars	S
83. Chassis members	S	88. Dampers (condition / leaks)	S	93. Corrosion protection	S
84. Power steering Electricity	S	89. Power steering pipes/gaiters	S	94. Corrosion – floor/chassis	NO

<b>REAR SUSPENSION / UNDERFRAME</b>					
95. Springs/suspension bars	S	99. Location rods/fixings	S	103. Sub-frames/mountings/axles	S

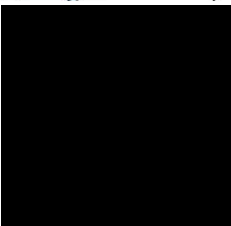

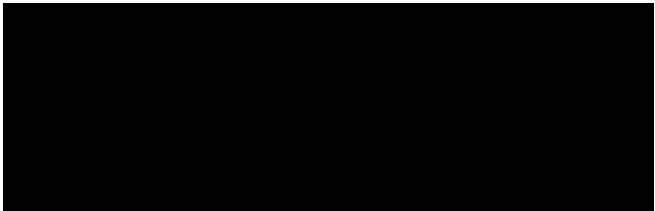

96. Anti roll bar	S	100. Bump stops/gaiters	S	104. Chassis members	S
97. Dampers/bushes	S	101. Wheel hubs/bearings	S	105. Corrosion protection	S
98. Suspension arms/fixings	S	102. Spheres/Pipes/Hoses	N/A	106. Corrosion – floor/chassis	NO

<b>CLUTCH / TRANSMISSION AUTO</b>					
107. Fluid/Oil leaks	NO	111. Casings/Axles/Differential(s)	S	115. Backlash	N/A
108. Cables/adjustments	S	112. Mountings	S	116. Gaiters	N/A
109. Hydraulic system	N/A	113. Drive shaft assembly	S	117. Propeller shaft(s)	N/A
110. Linkage (wear)	S	114. Universal/sliding joints	S	118. Prop.Bearings/Supports	N/A

<b>EXHAUST SYSTEM</b>					
119. Manifold(s)	N/A	121. Silencer(s)/Catalyst(s)	N/A	123. Joints/Couplings	N/A
120. Pipes	N/A	122. Heat shields/Mountings	N/A	124. System condition	N/A

<b>FUEL SYTEM</b>					
125. Tank	N/A	127. Fuel lines	N/A	129. Evidence of leaks	N/A
126. Tank fixings	N/A	128. Breather pipes	--	130.	N/A

<b>BRAKES</b>					
131. Master cylinder security	S	134. Flexible hoses	S	137. Hand/Parkbrake op/adjustment	S
132. Fluid leaks	S	135. Pipes/Connections	S	138. Hand/Parkbrake linkage	S
133. Servo/Power system	S	136. Discs/Pads/Drums	S	139. Pedal/Linkage	S

<b>WHEELS AND TYRES Type</b>					
140. Wheel Rims	S	Alloy			
141. Wheel Trims	S				
Tyres	Make	Size	Type / Construction	Min tread depth	
142. RH Front	UNIROYAL	245/45/19	Radial/Tubeless	6-7mm	S
143. LH Front	UNIROYAL	245/45/19	Radial/Tubeless	6-7mm	S
144. RH Rear Inside	UNIROYAL	245/45/19	Radial/Tubeless	6-7mm	S
145. RH Rear	UNIROYAL	245/45/19	Radial/Tubeless	6-7mm	S
146.					
147.					
148. Spare					N/A

<b>ROAD TEST</b>		
Finish Odom. Reading	<b>141183 MILES</b>	Conditions <b>Dry</b>
<b>Test Duration</b>	<b>15.2 Miles</b>	<b>Speed achieved up to 70 M.P.H.</b>

149. Final drive op./Noise level	S	156. Instrument/Controls function	S	163. Road holding/Stability	S
150. Gearbox operation/noise level	S	157. Steering wheel alignment	S	164. General steering/Handling	S
151. Engine performance	N/A	158. Clutch operation	N/A	165. Footbrake operation	S
152. Engine noise	N/A	159. 4WD operation	S	166. Hand/Parkbrake operation	S
153. Excess smoke	N/A	160. Cooling fan operation	N/A	167. Suspension noise	S
154. Overheating evidence	N/A	161. Steering effort	S	168. Warning lights	S
155. Auto changes/Kickdown/Inhib.	N/A	162. Hot restarting	S	169.	

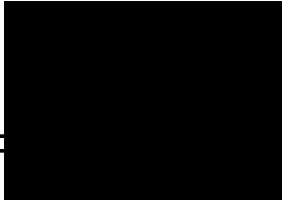

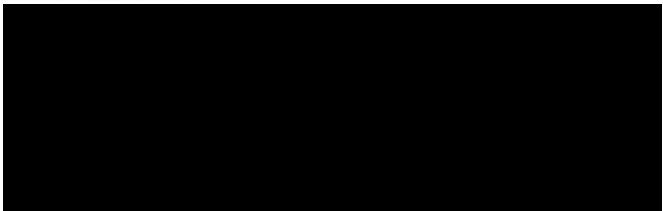

FINAL CHECK			
170. Oil leaks	NO	171. Coolant leaks	NO
		172.	

**Please read all pages of this report**

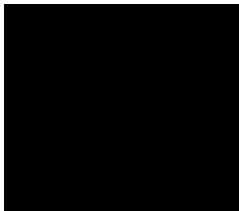

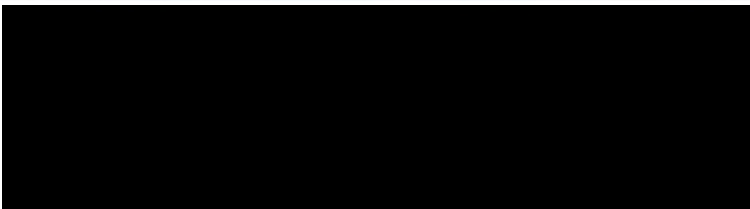

## Essential & Desirable Repairs

**It is strongly advised that the essential defects are investigated immediately or rectified prior to purchase of the vehicle and desirable repairs are carried out in the near future. Some defects may prove costly to rectify and this must be considered prior to purchase or authorising any remedial work.**

### Attention

Some vehicles are provided with a master key, which can be extremely costly to replace (sometimes in excess of £1000) as, in some cases, if the master key is missing the Engine Control Unit (ECU) may have to be replaced should you encounter problems. As well as this, some radios have codes to allow them to operate. Please satisfy yourself that you have all relevant keys and codes. You should also ensure you are given all relevant instruction manuals for the vehicle, radio, alarm and immobilisers as necessary

Item	Defect/Item requiring further investigation /rectification	D/X



Date:  
03/03/2026

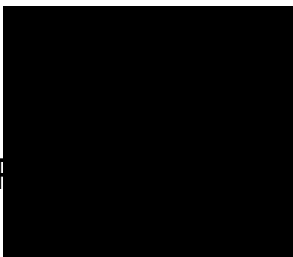

**F**













TESLA



MODEL S

MODEL S  
90D

0.0 mi	0 mi
6.8 mi	2.4 mi
141,090 mi	347 mi

16.68 °C

Navigation map

Not for publication

---

## REPORT TO LICENSING SUB-COMMITTEE

<b>Date of Hearing:</b>	<b>15.04.2026</b>
<b>Report of:</b>	<b>Nigel J Marston – Principal Licensing Officer</b>
<b>Decision Required:</b>	<b>To determine if the Licensed Driver is fit and proper to hold a taxi drivers' licence in accordance with the relevant Legislation.</b>
<b>Legislation:</b>	<b>Local Government (Miscellaneous Provisions) Act 1976 Town Police Clauses Act 1847</b>
<b>Licensed Driver:</b>	<b>[REDACTED]</b>

### 1. WHAT IS THE REPORT ABOUT?

- 1.1 To determine whether or not the Licensed Driver is a fit and proper person to hold a taxi drivers' licence.

### 2. BACKGROUND

- 2.1 The Licensing Authority was informed by Apple Taxis of a complaint that had been received on 11<sup>th</sup> March 2026, in relation to a booked journey on 9<sup>th</sup> March 2026. A copy of the complaint is attached as Appendix A.
- 2.2 The complaint alleges that the Licensed Driver swore at the female passengers and drove off with his door open ('the Incident').
- 2.3 One of the passengers was able to record the Incident, and this recording is attached at Appendix B.
- 2.4 The Principal Licensing Officer spoke with the Licensed Driver, via a telephone conversation, in relation to the Incident. During that conversation, the Licensed Driver accepted the complaint made against him and tried to justify his behaviour by claiming that the passengers were messing him around. The Principal Licensing Officer explained that having viewed the footage, the language used towards female passengers was totally inappropriate and the Incident was so serious that the Licensed Driver would be referred to Licensing Sub-Committee to determine if he remained a fit and proper person to hold a taxi driver's licence.

### 3. WHAT ARE THE LEGAL ASPECTS?

- 3.1 Under Section 61 of the Local Government (Miscellaneous Provisions) Act 1976 ('the Act') a district council may suspend or revoke or (on application therefore under section 46 of the Town Police Clauses Act 1847 ('Act of 1847') or section 51 of this Act, as the case may be) refuse to renew the licence of a

driver of a hackney carriage or private hire vehicle on any of the following grounds:

- (a) that he has since the grant of the licence—
  - (i) been convicted of an offence involving dishonesty, indecency or violence; or
  - (ii) been convicted of an offence under or has failed to comply with the provisions of the Act of 1847 or of this Part of this Act;
- (a) that he has since the grant of the licence been convicted of an immigration offence or required to pay an immigration penalty; or
- (b) any other reasonable cause.

- 3.2 The evidential burden is not on the Licensed Driver to prove he is a fit and proper person but for the Licensing Sub-Committee to be satisfied on the balance of probabilities that the Licensed Driver is no longer a fit and proper person.
- 3.3 The Licensing Sub-Committee may suspend or revoke a taxi driver's licence where they are not satisfied that the licence holder is a fit and proper person to drive a taxi.
- 3.4 If the Licensed Driver is suspended the suspension period is determined by the Licensing Sub-Committee as they determine appropriate based on the circumstances of the case. The Licensing Sub-Committee may require the Licensed Driver to complete specified training.
- 3.5 If the Licensed Driver's licence is suspended or revoked the suspension or revocation shall commence at the end of the period of 21 days beginning with the day in which the Licensed Driver has received written notice of the Licensing Sub-Committee decision, unless there is an immediate need to protect the public in which case the suspension or revocation will have immediate effect.
- 3.6 The Licensing Sub-Committee must have regard to the Statutory taxi and private hire standards updated on 25<sup>th</sup> November 2022 and issued by the Secretary of State for Transport under section 177(1) of the Policing and Crime Act 2017 ('Statutory Guidance')
- 3.7 The Statutory Guidance provides information on the fit and proper test at Paragraph 5.4 states:

*'Licensing authorities have a duty to ensure that any person to whom they grant a taxi or private hire vehicle driver's licence is a fit and proper person to be a licensee. It may be helpful when considering whether an applicant or licensee is fit and proper to pose oneself the following question:*

*Without any prejudice, and based on the information before you, would you allow a person for whom you care, regardless of their condition, to travel alone in a vehicle driven by this person at any time of day or night?*

*If, on the balance of probabilities, the answer to the question is no, the individual should not hold a licence.'*

- 3.8 The Licensing Sub-Committee may impose penalty points in accordance with the Council's Taxi Policy which is explained further below.

#### **4. WHAT ARE THE POLICY ASPECTS?**

- 4.1 The Licensing Sub-Committee must have regard to the Council's the Practices and Procedures for the control of Hackney Carriage and Private Hire Vehicles, Drivers and Operators and the Code of Conduct for Licensed Drivers ('Taxi Policy').
- 4.2 The relevant provisions of the Taxi Policy are as follows:
- *N.1.1*
    - (c) The driver shall at all times be clean and tidy, and must behave in a polite manner.*
    - (d) all reasonable precautions must be taken to ensure the safety of passengers conveyed in, entering or alighting the vehicle.*
  - *J.7.1(c) drive with due care and consideration for other road users and pedestrians, and in particular shall not use a handheld mobile phone whilst driving.*
  - *J.2.1 Licence holders shall endeavour to promote the good image of the Hackney Carriage and Private hire trade by:*
    - a. complying with this Code of Good Conduct;*
    - b. complying with all the Conditions of their Licence and the Councils Hackney Carriage and Private Hire Licensing Policies;*
    - c. behaving in a civil, orderly and responsible manner at all times*
- 4.3 A copy of the driver's conditions issued to this driver at renewal on 20<sup>th</sup> April 2024 is attached as Appendix C.
- 4.4 The Licensing Sub-Committee must satisfy itself that all Licensed Drivers are Fit and Proper persons to hold a Drivers Licence. In so doing, it will have regard to all relevant factors such as convictions, cautions, warnings and reprimands including those that are "spent Convictions" under the Rehabilitation of Offenders Act 1974.
- 4.5 The Taxi Policy does state that there may be occasions where it is appropriate to depart from these guidelines when considering whether a driver is fit and proper. For example, where the offence is a 'one-off' and there are mitigating circumstances or alternatively where there are many or continuous offences which may show a pattern of offending and unfitness

- 4.6 In July 2023, the Council adopted a points based disciplinary system which officers and the Licensing Sub-Committee may apply to licensed drivers. A copy is attached as Appendix D to this report.

Relevant to this report, the following can be considered.

Details of Misconduct	Points applicable
Unsatisfactory behaviour or conduct of a driver	1-12
Failure to behave in a civil and orderly manner, or bringing the trade into disrepute	1-12

- 4.7 When issued, the penalty points will remain 'live' for a rolling period of 36 months from the date they were imposed.
- 4.8 If 12 penalty points are imposed on an individual licence in any one 36-month rolling period the driver will appear in front of the Licensing Sub-Committee where appropriate action will be taken in accordance with the Taxi Policy.

## 5. OPTIONS

- 5.1 The Licensing Authority would make the following recommendations:

The Licensing Sub-Committee may find either:

- i) That the Licensed Driver is a fit and proper person to hold a taxi driver's licence and the licence should remain in place; or
- ii) That the Licensed Driver is a fit and proper person to hold a taxi drivers licence and the licence should remain in place but a written warning shall be issued by the Chair of the Licensing Sub Committee with regard to future conduct; or
- iii) That the Licensed Driver is a fit and proper person to hold a taxi drivers licence and the licence should remain in place but a written warning with regard to future conduct together with the issue of penalty points from the Chair of the Licensing-Sub-Committee; or
- iv) That the Licensed Driver is not a fit and proper person to hold a taxi driver's licence but that the licence should remain in place subject to a period of suspension so as to deter any future misconduct. In addition, penalty points may be issued by the Chair of the Licensing Sub Committee; or
- v) That the Licensed Driver is not a fit and proper person to hold a taxi driver's licence but that the licence should remain in place subject to a period of suspension until such time as the Licensed Driver has completed appropriate training. In addition, penalty points may be issued by the Chair of the Licensing Sub Committee; or
- vi) That the Licensed Driver is not a fit and proper person to hold a taxi driver's licence and should have his licence revoked;

Where the Licensing Sub-Committee determine that the Licensed Driver is not a fit and proper person to hold a driver's licence and there is a need to provide immediate protection to the public the licence will be suspended or revoked with immediate effect.

## **6. RECOMMENDED**

6.1 It is recommended that the Licensing Sub-Committee determine whether or not the Licensed Driver is a fit and proper person to hold a taxi driver's licence, having regard to the Licensed Drivers' representations and all other relevant information submitted together with the Taxi Policy.

Simon Lane – Service Lead – Environment and Waste  
Author: Nigel J Marston

### **Local Government (Access to Information) Act 1985 (as amended)**

Background papers used in compiling this report: None.

This page is intentionally left blank

Good morning,

I would like to make you aware of a complaint that has been received about driver HD363.

The initial complaint explained that the driver referred to the 2 young girls as “a fu\*\*ing bi\*\*h” and “a fu\*\*ing c\*\*t” while driving off with his passenger door open.

We have since been unable to contact the driver to request a meeting to discuss the incident however understandably the customer wants a response and isn't very happy.

The journey took place on Monday 9<sup>th</sup> March at 22:55. I have since contacted the complainant to ask if I can share their details directly with yourselves, so they are able to complete a witness statement. They have also sent us video evidence which you will find attached.

Kind Regards



General Manager

Apple Central Taxis (SW) Limited (09018290)

---

 3-4 Isambard Parade, St. Davids Station, Exeter, EX4 4BX

 01392 666 666



 <http://www.appletaxisexeter.co.uk>

---

This page is intentionally left blank

**Town Police Clauses Act 1847**  
**Local Government (Miscellaneous Provisions) Act 1976**

Standard Licence Conditions for [REDACTED] Licence Number [REDACTED]

**Code of Good Conduct for Licensed Drivers**

**1 Code of Good Conduct for Licensed Drivers**

In order to promote its licensing objectives as regards hackney carriage and private hire licensing, this Council has adopted the following Code of Good Conduct, which should be read in conjunction with the other statutory and policies requirements set out in this document.

**2 Responsibility to the Trade**

Licence holders shall endeavour to promote the good image of the Hackney Carriage and Private hire trade by:

- i complying with this Code of Good Conduct;
- ii complying with all the Conditions of their Licence and the Councils Hackney Carriage and Private Hire Licensing Policies;
- iii behaving in a civil, orderly and responsible manner at all times

**3 Responsibility to Clients**

Licence Holders shall:

- i. maintain their vehicles in a safe and satisfactory condition at all times;
- ii. keep their vehicles clean and suitable for hire to the public at all times;
- iii. attend punctually when undertaking pre-booked hiring;
- iv. assist, where necessary, passengers into and out of vehicles;
- v. offer passengers reasonable assistance with luggage.

**4 Responsibility to Residents**

To avoid nuisance to residents when picking up or waiting for a fare, a driver shall:

- i. not sound the vehicle's horn illegally;
- ii. keep the volume of car stereo/ audio system and VHF radios to a minimum;
- iii. switch off the engine if required to wait;
- iv. take whatever additional action is necessary to avoid disturbance to residents in the neighbourhood.

**5 Behaviour on the ranks**

At taxi ranks and other places where hackney carriages ply for hire by forming queues, drivers shall, in addition to the requirements above:

- i. Rank in an orderly manner and proceed along the rank in order and promptly;
- ii. Remain in the vehicle.
- iii. Act in accordance with the direction of taxi marshals
- iv. Wait their turn to pick up fare

**6 Private Hire Offices**

At private hire offices a licence holder shall:

- i. not undertake servicing or repairs of vehicles;
- ii. not allow their car stereo/ audio system or VHF radios to cause disturbance to residents of the neighbourhood;
- iii. take whatever additional action is necessary to avoid disturbance to residents of the neighbourhood which might arise from the conduct of their business.

**7 General**

Drivers shall:

- i. Pay attention to personal hygiene and dress so as to present a professional image to the public;
- ii. be polite, helpful and fair to passengers;
- iii. drive with care and due consideration for other road users and pedestrians and in particular shall not use a hand held mobile phone whilst driving;
- iv. obey all Traffic Regulation Orders and directions at all times;
- v. not smoke in the vehicle;
- vi. not consume alcohol immediately before or at any time whilst driving or being in charge of a hackney Carriage or Private Hire Vehicle;

- vii. not drive while having misused legal or illegal drugs;
- viii. fulfil their responsibility to ensure compliance with legislation regarding the length of working hours.

## **Dress and appearance of Licensed Drivers**

### **1 Dress and appearance of Licensed Drivers**

Exeter City Council is committed to encouraging the professional image of the hackney carriage and private hire trade, and considers that drivers of licensed vehicles are vocational drivers. The Council considers, therefore, that drivers should wherever possible conform to a minimum standard of dress, as set out below, in order to raise the profile of the licensed trade. The Council does not impose such standards by way of conditions to any licence. It is expected, however, that such standards shall be maintained at all times.

### **2 Acceptable Standards of Dress**

Acceptable - will include long or short sleeved shirts with collars, skirts, dresses, long trousers, shoes or sandals with socks.

### **3 Unacceptable Standards of Dress**

Unacceptable - torn jeans, shorts, jogging bottoms, trainers, singlets or bathing costumes. The following are also deemed to be unacceptable: a. Clothing or footwear, which is unclean or damaged. b. Clothing printed with words, logos or graphics, which might offend c. Studs or sharp-edged clothing d. Beach-type footwear (e.g.: flip-flops) e. Footwear with pronounced heels

### **4 Footwear**

Footwear should fit around the heel of the foot. Safety shoes with protected toecaps are recommended.

## **Driver's Conditions**

### **1 Conduct of Driver**

The holder of a private hire driver's licence shall comply with the following conditions, which should be read in conjunction with the Code of Good Conduct in Appendix L:

- i. The private hire vehicle shall be presented in a roadworthy and clean condition for each journey.
- ii The driver must wear the lapel badge provided by the Council at all times when in charge of a licensed vehicle, and in such a position and manner as to be plainly visible.
- iii The driver shall at all times be clean and tidy, and must behave in a polite manner.
- iv All reasonable precautions must be taken to ensure the safety of passengers conveyed in, entering or alighting from the vehicle.
- v Assistance must be given with the loading and unloading of luggage.
- vi Unless otherwise directed by the hirer, the shortest possible route must be taken to complete the journey.
- vii The vehicle must only be driven with the consent of the proprietor of the vehicle.
- viii The driver must comply with any hirer's request not to smoke, drink or eat in the vehicle, or play any radio or sound equipment, which is not connected with the operation of the private hire business.
- ix The driver must ensure that the noise emitted from any sound equipment in the vehicle does not cause annoyance to any persons, whether inside or outside the vehicle.
- x The driver shall attend and depart punctually for a private hire booking, and shall not operate the horn as a means of signalling that the vehicle has arrived.
- xi A driver must not cause or permit the vehicle to stand on a road or in a public place as to suggest that it is plying for hire, or use any hackney carriage stand within the Exeter City Council area.
- xii A driver must not solicit any person to hire or be carried for hire, or accept an offer for the hire of the vehicle except where that is first communicated to the driver by telephone.
- xiii Other licensed drivers must not be obstructed.

### **2 Fares**

The driver/operator of a private hire vehicle shall make their own agreement with the hirer as to the fare for a particular journey.

The driver shall, if requested by the hirer, provide him/her with a receipt for the fare paid.

### **3 Duties of Licence Holder**

- i. The private hire driver's licence must be delivered immediately to the proprietor concerned, at the beginning of the employment.
- ii. Upon ceasing employment as a licensed driver, the licence-holder must surrender to the Council the licence and badge issued by the Council, together with the plate when appropriate.
- iii. The driver must notify the Council, within 7 days, of any change of address.
- iv. The driver must notify the Council, within a period of 7 days, of any conviction or caution for an offence, or of any receipt of a fixed penalty, imposed on him/her whilst the licence is in force.
- v. The driver shall notify the Council of any accident, or damage caused to the licensed vehicle, within 24 hours of the event.

### **4 Lost Property**

Immediately after the termination of every hiring, the driver must carry out a search of the vehicle for property that may have inadvertently been left there by the hirer.

If the driver finds any property in the licensed vehicle, he must deliver it to the front office of Heavitree Road Police Station. On no account should a driver retain any property found in a licensed vehicle.

The driver shall be entitled to receive from the owner of the lost property an amount equal to 5 pence in the pound of its estimated value, to a maximum of £10.00, or alternatively the fare for the distance from the place where the property was found to the Exeter Police Station, Sidmouth Road, whichever is the greater.

### **5 The Carriage of Animals**

- i A driver must not carry in a licensed vehicle any animal, which belongs to, or is being looked after by, themselves, the owner or operator of the vehicle while it is being used as a Private Hire vehicle.
- ii Animals in the custody of passengers may be carried, at the driver's discretion, provided they are restrained in a safe manner.
- iii. A driver must, however carry assistance dogs when necessary. Assistance dogs include guide dogs for the blind, hearing dogs for the hard of hearing, and other assistance dogs, which assist disabled people with a physical impairment.
- iv. Any licensed driver with a medical condition, which may be exacerbated by dogs, may apply for exemption from this condition. A certificate of exemption will be supplied on production of suitable medical evidence.



	Details of the Misconduct	Points Applicable	Driver	Vehicle Owner or Operator
1	Providing false or misleading information on licence application form / failing to provide relevant information or pay the relevant fee	6	✓	✓
2	Failure to notify, in writing, the Council of a change of address within 7 calendar days	3	✓	✓
3	Refusal to accept hiring without reasonable cause	6	✓	
4	Unreasonable prolongation of journeys or any misconduct regarding the charging of fares	6	✓	
5	Plying for hire by Private hire drivers or Hackney Carriage drivers plying for hire outside the district	9	✓	✓
6	Private hire vehicle parking or waiting on a taxi rank	9	✓	✓
7	Inappropriate behaviour at a taxi rank	1-12	✓	
8	Leaving a taxi unattended at a rank	4	✓	
9	Using unlicensed vehicle or using a licensed vehicle without insurance or without a valid MOT	12	✓	✓
10	Failure to produce relevant documents within timescales when requested by an Authorised Officer	4	✓	✓
11	Unsatisfactory condition of vehicle, interior or exterior	4	✓	✓
12	Failure to undergo the MOT on time	6		✓
13	Failure to provide proof of insurance cover when requested	6		✓
14	Failure to produce Hackney Carriage or Private Hire vehicle for testing when required	4		✓
15	Using a vehicle subject to a suspension order issued by an Authorised Officer or a police officer	12	✓	✓
16	Using a vehicle for which the licence has been suspended or revoked	12	✓	✓
17	Failure to report, in writing, within 72 hours, accident or damage to licensed vehicle, which would cause the vehicle to breach licence conditions	4	✓	✓
18	Carrying more passengers than stated on the vehicle licence	6	✓	
19	Failure to display external/internal licence plate in a fixed position or failure to display appropriate door signs	6	✓	✓
20	Carrying an offensive weapon in the vehicle	12	✓	
21	Failure to notify a transfer of Private Hire or Hackney Carriage vehicle licence within 14 days of transfer	4		✓
22	Failure to carry fire extinguisher	4		✓

	Details of the Misconduct	Points Applicable	Driver	Vehicle Owner or Operator
23	Failure to carry first aid kit	3		✓
24	Displaying unsuitable or inappropriate sited signs or unauthorised advertisements in or on the vehicle	3		✓
25	Failure to use authorised roof light	4	✓	
26	Failure to maintain records in a suitable form of the commence and cessation of work of each driver each day	4		✓
27	Failure to produce on request records of drivers' work activity	4		✓
28	Using a non-approved or non-calibrated taximeter	6	✓	✓
29	Obstruction of an authorised officer or police officer wishing to examine a licensed vehicle	12	✓	✓
30	Evidence of smoking in vehicle	3	✓	✓
31	Eating whilst a passenger is in the vehicle	3	✓	✓
32	Displaying any feature on private hire vehicle that may suggest that it is a Hackney Carriage	6		✓
33	Using a vehicle, the appearance of which suggests that it is a Taxi	6		✓
34	Failure to carry an assistance dog without requisite medical exemption certificate	12	✓	✓
35	Driver not holding a current DVLA licence	12	✓	✓
36	Failure to have the driver's badge clearly displayed	4	✓	
37	Failure to notify, in writing, a change in medical circumstances	6	✓	
38	Unsatisfactory appearance of driver	4	✓	
39	Failure to observe rank discipline	3	✓	
40	Failure to maintain proper records of private hire vehicles	3		✓
41	Failure to keep or produce records of Private Hire bookings or other documents required to be kept or produced	6		✓
42	Misleading use of the words 'Taxi' or 'Cab' on advertising materials	3		✓
43	Failure to issue receipt on request	6	✓	✓
44	Using a licensed vehicle in a dangerous condition	9	✓	✓
45	Failure to return vehicle licence plate within 7 days after due notice following expiry, revocation or suspensions of such licence	4		✓
46	Unsatisfactory behaviour or conduct of a driver	1-12	✓	
47	Failure to notify the Council in writing, of any motoring or criminal convictions within 21 days or conviction or cautions during period of current licence	6	✓	✓

	Details of the Misconduct	Points Applicable	Driver	Vehicle Owner or Operator
48	Failure to behave in a civil and orderly manner, or bringing the trade into disrepute	1-12	✓	✓
49	Failure to provide reasonable assistance to a passenger	1-12	✓	✓
50	Carrying two or more separate fares without the appropriate consent	9	✓	✓
51	Failure to display a correct up to date fare card	3	✓	✓
52	Failure to carry a legal spare wheel (or appropriate alternative) and the necessary tools to fit the spare wheel	4	✓	✓
53	Failure to attend punctually at appointed time and place without sufficient cause	4	✓	✓
54	A licensed vehicle with a bald or dangerous or defective tyre (4 points per tyre)	4	✓	✓
55	Failure to submit licence renewal application including documents and attendance at a vehicle inspection	6	✓	✓
56	Failure to display an applicable fare card AND the Councils valid fare card together	3	✓	✓
57	Waiting or stopping on a double yellow area, bus stop or private land (without the owner's permission) unless requested by a paying customer present in the vehicle	3	✓	
58	Driving whilst using a mobile phone	12	✓	

\*- discretionary points up to a maximum of 6 points can be issued by officers, but greater awards of points can only be issued by the Licensing Panel.

Officers may refer any mandatory award of points to Members where there are aggravating features to any case.

Ticks indicate potential recipients of points for infringements, but are not limited to those only. Certain cases may result in drivers and/or proprietors and/or operators receiving penalty points. Points may be awarded to one or several persons depending upon the circumstances of the case, but each case will be considered on its individual merits.

This page is intentionally left blank